



# CHUNLAN

## COMMERCIAL AIR CONDITIONERS

– 2016 –



**JIANGSU CHUNLAN IMP.&EXP.CO.,LTD.**

10Th Floor, Chunlan Global Business Center,Taizhou, Jiangsu,China

General Manager Hotline:+86-523-86993086

FAX: +86-523-86662193

E-mail: [gyj@chunlan.com](mailto:gyj@chunlan.com)

Website:<http://www.chunlan.com>

Edition:2016 0401

Note:Due to continuous R&D,designs,features and specifications are subject to change without prior notice. As per specific product data,contract should be taken as final and binding.





## CONTENS

01	Introduction
03	Floor Standing Series
07	Cassette Series
11	Duct Series
19	Multi-Connected DC Inverter Series
31	Modular Air Cooled ( Heated ) Water Chiller Series
39	Water Cooled Screw Chiller Series
45	Water Cooled Scroll Chiller Series
65	Enclosure Series
69	Air Source Water Heater Series
71	Dehumidifier Series

## Chunlan Introduction

As one of the largest enterprise in china .Chunlan (Group) corporation is a diversified high-tech and modern corporation that specializes in manufacturing, scientific research, investment as well as trading areas with multi independent subsidiaries in china and abroad.

The "Global Open Scientific Research Platform" consisted of Chunlan educational/research institutions ,Chunlan Academy, Chunlan Post-doctoral Work Station and state-level technology development center is the important base for the world frontier science and technology research.

Chunlan industries cover machinery, air conditioner, new energy, real estate, hotel industry, commerce, finance and investment, etc; the main products include residential air conditioner, commercial air conditioner, compressor, high- energy power battery and power management system, power system, mechanical processing and power products, residential and commercial real estate and so on.

As a "technology leader" enterprise, Chunlan Group undertake many national science and technology projects, not only leading the R&D of energy saving, environmental friendly, intelligent, healthy home appliances in domestic market, but also promoting the development of china's new energy industry. The high power batteries which have been included in the national major science and technology, are widely used in new energy cars, high speed locomotives, intelligent robot, large ships, etc, and "the Key Technology of Energy Saving for Hybrid Bus" won the National Technology Progress Award"; Chunlan storage power station and solar energy power station system are successfully applied in Shanghai world expo etc; The leading edge science and technology products -- chunlan fuel battery, the human genome repair and depth and height radio wireless communication equipment have made great breakthrough.

In the first decade of the new century, chunlan will comprehensively integrate and optimize the resources, accelerate the global prosecution, fulfill the social responsibility, create the low- carbon and cycle economy, build a friendly and harmonious enterprise, make a greater contribution to the better and faster development of China's economy and various undertakings.

New realm, new strategy and new development. Chunlan is proudly moving forward to its ultimate strategic goal of becoming a world -famous diversified corporation.



## Seven industries



## Chunlan Commercial Air conditioner Introduction

Chunlan commercial air conditioner is one of the most important industries of chunlan group. Chunlan Air Conditioning Equipment Co., LTD. is the earliest manufacturer of large commercial air conditioner in china. The main products include: commercial floor standing series, cassette series, household water chiller series, modular air cooled water chiller series, centralized control multi-connected inverter series, modular duct series, multi-connected air-conditioning series, duct type air conditioner series, dehumidifier series, portable air conditioner series, heat pump water heater series and so on.

For many years, the products of the company have been well received by the domestic users. Besides, the products have also been sold to more than 100 overseas countries and regions and the export volume has reached one million units.

Chunlan not only always upholds the spirit of scientific -technical progress, but also builds ISO9001 international quality management system and ERP enterprise management system. The products have passed the 3C certificate, CE certificate, CB certificate etc.

Adhering to the 50 years design and manufacturing experience, the company has already developed numerous commercial air conditioners which proprietary and intellectual property rights.

Depending on the cascade scientific research system composed of chunlan institute - postdoctoral research station and research institution, the company keeps on aiming at the world advanced technology and constantly improving the scientific innovation ability and quality management ability of the products to meet customers' demands.



## History of Commercial Air Conditioner

- 1989 Chunlan took the lead in developing the first 10Hp split floor standing unitary air conditioner
- 1995 Jiangsu Chunlan Refrigeration Equipment CO., LTD. was established
- 1995 Chunlan 10HP unitary air conditioner won the "National New Product" certificate
- 2001 Chunlan developed the new type of intelligent scroll compressor module for central air conditioner, and applied it to the central air cooled water chiller unit
- 2002 Jiangsu Chunlan Refrigeration Equipment CO., LTD. and Jiangsu Chunlan Dehumidification Equipment CO., LTD. were combined as Chunlan Refrigeration Equipment CO., LTD
- 2002 Chunlan commercial air conditioner passed ISO9001 quality management system
- 2005 Chunlan developed the central air conditioner which could connect 16 sets of indoor units
- 2006 Chunlan intelligent multi-connected central air conditioner passed the evaluation, the technology reached the international advanced level
- 2007 Chunlan intelligent multi-connected central air conditioner won the "National Key New Product" certificate
- 2009 Jiangsu Chunlan Refrigeration Equipment co., LTD. was renamed Jiangsu Chunlan Air Conditioning Equipment CO., LTD
- 2011 Chunlan commercial air conditioner has passed CCC certificate of the CQC for 8 years

### CERTIFICATES





Floor Standing Air Conditioners



**Strong capability, long distance air supply**

Chunlian floor standing type air conditioner is excellent for the strong cooling or heating capability and long distance which up to 15m air supply, which can make the room cool / warm no matter how large space is.



**Intelligent temperature control**

Constant temperature is guaranteed by intelligent precise temperature control, which will decide the cooling mode automatically according to the difference of ambient temperature and room temperature

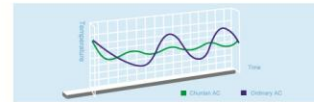

**LED full screen dynamic display**

LED full screen dynamic display, with bright and dazzling color, clear and super innervation.



**Low noise**

By application of the finite element analysis technology and air flow field stimulation technology, noise from vibration of the compressor and other moving parts is decreased a lot



**High efficient compressor**

Chunlian air conditioner adopts famous brand and high efficient compressor to improve the refrigeration efficiency, the efficiency is 5% more than the ordinary compressor.

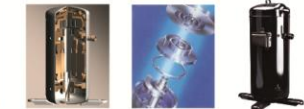

**High-density air filters**

Adopting high density air filter, effectively filtrate dust, peculiar smell, which removes dust up to 78.6%, better than the most ordinary filters. The filter keeps the inside of the unit cleaner and than translates into cleaner air.

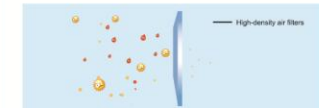

**Application Area:** shops, factories, offices, clubs, restaurants and other places.





A

CF-42/AS



B

CF-42R/AdS

CF-42R/AwAdS

CF-42/AHS



CF-42R/AHdS

CF-42R/AHWAdS

CF-42/BS

CF-42R/BdS

CF-42R/BWAdS

CF-42/BHS

CF-42R/BHdS

CF-42R/BHWAdS



CF-96/FS



CF-96R/FdS

CF-96R/FWAdS

CF-96R/HS

CF-96R/HdS

Performance	Model	CF-42/AS	CF-42R/AdS	CF-42R/AWAdS	CF-42/AHS	CF-42R/AHdS	CF-42R/AHWAdS
Refrigerant		R22	R22	R410a	R22	R22	R410a
Cooling Capacity	Btuh	42000	42000	42000	42000	42000	42000
Heating Capacity	Btuh	45000(8200)	45000(8200)	45000(8200)	45000(8200)	45000(8200)	45000(8200)
Power supply	Ph, V~, Hz	3,380,50	3,380,50	3,380,50	3,380,50	3,380,50	3,380,50
Rated Cooling Power Input	W	4700	4700	4320	3900	3900	3900
Rated Heating Power Input	W	4700(2400)	4700(2400)	4420(2400)	3900(2400)	3900(2400)	3900(2400)
Rated Cooling Operating Current	A	7.1	7.1	7.4	6.0	6.0	6.0
Rated Heating Operating Current	A	7.2(11)	7.2(11)	7.5(11)	6.0(11)	6.0(11)	6.0(11)
Air Flow Volume(indoor)	m <sup>3</sup> /h	1600	1600	1600	1600	1600	1600
Noise Level (dB(A))	Indoor	54	54	54	52	52	52
	Outdoor	60	60	60	60	60	60
Net Dimensions WxDxH	Indoor (mm)	540x370x1820	540x370x1820	540x370x1820	540x370x1820	540x370x1820	540x370x1820
	Outside (mm)	1000x410x1157	1000x410x1157	1000x410x1157	1000x410x1157	1000x410x1157	1000x410x1157
Net Weight (kg)	Indoor/Outdoor	51/99	51/103	51/103	51/109	51/113	51/113
Packing Dimensions WxDxH	Indoor (mm)	635x470x1920	635x470x1920	635x470x1920	635x470x1920	635x470x1920	635x470x1920
	Outdoor (mm)	1100x480x1355	1100x480x1355	1100x480x1355	1100x480x1355	1100x480x1355	1100x480x1355
Gross Weight (kg)	Indoor/Outdoor	60/114	60/118	60/118	60/124	60/128	60/128
Applicable Area	m <sup>2</sup>	60-120	60-120	60-120	60-120	60-120	60-120
Loading Quantity (set)	20/40/40HQ	18/38/48	18/38/48	18/38/48	18/38/48	18/38/48	18/38/48

Performance	Model	CF-42/BS	CF-42R/BdS	CF-42R/BWAdS	CF-42/BHS	CF-42R/BHdS	CF-42R/BHWAdS
Refrigerant		R22	R22	R410a	R22	R22	R410a
Cooling Capacity	Btuh	42000	42000	42000	42000	42000	42000
Heating Capacity	Btuh	45000(8200)	45000(8200)	45000(8200)	45000(8200)	45000(8200)	45000(8200)
Power supply	Ph, V~, Hz	3,380,50	3,380,50	3,380,50	3,380,50	3,380,50	3,380,50
Rated Cooling Power Input	W	4700	4700	4320	3900	3900	3900
Rated Heating Power Input	W	4700(2400)	4700(2400)	4420(2400)	3900(2400)	3900(2400)	3900(2400)
Rated Cooling Operating Current	A	7.1	7.1	7.4	6.0	6.0	6.0
Rated Heating Operating Current	A	7.2(11)	7.2(11)	7.5(11)	6.0(11)	6.0(11)	6.0(11)
Air Flow Volume(indoor)	m <sup>3</sup> /h	1600	1600	1600	1600	1600	1600
Noise Level (dB(A))	Indoor	54	54	54	52	52	52
	Outdoor	60	60	60	60	60	60
Net Dimensions WxDxH	Indoor (mm)	540x370x1820	540x370x1820	540x370x1820	540x370x1820	540x370x1820	540x370x1820
	Outside (mm)	1000x410x1157	1000x410x1157	1000x410x1157	1000x410x1157	1000x410x1157	1000x410x1157
Net Weight (kg)	Indoor/Outdoor	51/99	51/103	51/103	51/109	51/113	51/113
Packing Dimensions WxDxH	Indoor (mm)	635x470x1920	635x470x1920	635x470x1920	635x470x1920	635x470x1920	635x470x1920
	Outdoor (mm)	1100x480x1355	1100x480x1355	1100x480x1355	1100x480x1355	1100x480x1355	1100x480x1355
Gross Weight (kg)	Indoor/Outdoor	60/114	60/118	60/118	60/124	60/128	60/128
Applicable Area	m <sup>2</sup>	60-120	60-120	60-120	60-120	60-120	60-120
Loading Quantity (set)	20/40/40HQ	18/38/48	18/38/48	18/38/48	18/38/48	18/38/48	18/38/48

Performance	Model	CF-96/FS	CF-96R/FdS	CF-96R/FWAdS	CF-96/HS	CF-96R/HdS
Refrigerant		R22	R22	R410a	R22	R22
Cooling Capacity	Btuh	96000	96000	96000	96000	96000
Heating Capacity	Btuh	100000(20500)	100000(20500)	100000(20500)	100000(20500)	100000(20500)
Power supply	Ph, V~, Hz	3,380,50	3,380,50	3,380,50	3,380,50	3,380,50
Rated Cooling Power Input	W	19100	19100	19100	9100	9100
Rated Heating Power Input	W	9400(6000)	9400(6000)	9200(6000)	9000(6000)	9000(6000)
Rated Cooling Operating Current	A	19.8	19.8	20.0	18.5	18.5
Rated Heating Operating Current	A	19(11)	19(11)	20(11)	18.4(11)	18.4(11)
Air Flow Volume(indoor)	m <sup>3</sup> /h	4200	4200	4200	4200	4200
Noise Level (dB(A))	Indoor	61	61	61	61	61
	Outdoor	63	63	63	63	63
Net Dimensions WxDxH	Indoor (mm)	1200x400x1813	1200x400x1813	1200x400x1813	1200x400x1813	1200x400x1813
	Outside (mm)	980x980x1061	980x980x1061	980x980x1061	980x980x1061	980x980x1061
Net Weight (kg)	Indoor/Outdoor	140/182	140/182	145/182	150/172	150/172
Packing Dimensions WxDxH	Indoor (mm)	1295x500x1977	1295x500x1977	1295x500x1977	1295x500x1977	1295x500x1977
	Outdoor (mm)	1028x1028x1215	1028x1028x1215	1028x1028x1215	1028x1028x1215	1028x1028x1215
Gross Weight (kg)	Indoor/Outdoor	155/192	155/192	160/212	170/222	170/222
Applicable Area	m <sup>2</sup>	150-200	150-200	150-200	150-200	150-200
Loading Quantity (set)	20/40/40HQ	7/14/22	7/14/22	7/14/22	7/14/22	7/14/22

- The data listed in the form only for reference, and the specific parameter shall refer to product nameplates.
- The applicable area of air conditioner is related to room orientation, insulation level, height of the building, the size and amount of the doors and windows, so that the applicable area is just for reference.
- Chunlian reserves the right to change the product design, specifications, and parameters. There is no specific notice if there appears any adjustment, please refer to product specifications and product nameplates.



Cassette Air Conditioners

**Intelligent control, energy-saving**

Microcomputer system intelligent control, each component is always in the best state during the operation process, it also has many kinds of operation protection function to detect various faults. Which make it easier to finding faults, thus automatically protect the operation of the unit.



**Intelligent temperature control**

Constant temperature is guaranteed by intelligent precise temperature control, which will decide the cooling mode automatically according to the difference of ambient temperature and room temperature.

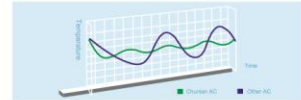

**Low noise**

By application of the finite element analysis technology and air flow field stimulation technology, noise from vibration of the compressor and other moving parts is decreased a lot.



**High position water drainage operation**

Maglev switch and special pump for indoor unit are designed according to the character of water drain from condenser. Water will be drained in high position regularly with relevant protections

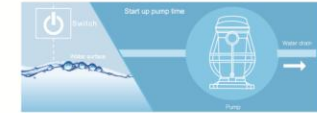

**High efficient compressor**

Chunlan air conditioner adopts famous brand and high efficient compressor to improve the refrigeration efficiency, the efficiency is 5% more than the ordinary compressor.



**High-density air filters**

Adopting high efficient air filter, which removes dust up to 78.6%, better than the most ordinary filters. The filter keeps the inside of the unit cleaner and than translates into cleaner air.

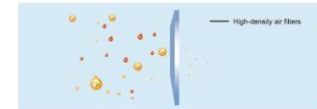

**Application Area:** shops, factories, offices, clubs, restaurants and other places.



Cassette Air Conditioner



CC-24 CC-24R

CC-24R/Wa

CC-42/-S CC-42R/-S CC-42R/WaS

CC-42/HS CC-42R/HS CC-42R/HWaS

Performance		Model	CC-24(R)	CC-42(R)/-S	CC-42(R)/HS
Refrigerant			R22	R22	R22
Cooling Capacity	Btu/h		24000	42000	42000
Heating Capacity	Btu/h		26000	45000	45000
Power supply	Ph. V~, Hz		1,220.50	3,380.50	3,380.50
Rated Cooling Power Input	W		2750	4700	3900
Rated Heating Power Input	W		2750	4800	3900
Rated Cooling Operating Current	A		12.5	7.1	6.0
Rated Heating Operating Current	A		12.5	7.2	6.0
Air Flow Volume(indoor)	m³/h		1200	1750	1750
Noise Level (dB(A))	Indoor		48	52	52
	Outdoor		60	60	60
Net Dimensions W×D×H	Inside (mm)		950×950×305	950×950×365	950×950×365
	Outside (mm)		950×310×745	1000×410×1157	1000×410×1157
	Indoor/Outdoor		39/64	44/103	44/113
Packing Dimensions W×D×H	Indoor (mm)		900×900×305	905×915×370	905×915×370
	Panel (mm)		1045×1015×170	1045×1015×175	1045×1015×175
	Outdoor (mm)		1125×420×875	1100×480×1355	1100×480×1355
Gross Weight (kg)	Indoor/Outdoor		48/72	40(13)/118	40(13)/128
Applicable Area	m²		40-56	60-120	60-120
Loading Quantity (set)	20/40/40/HQ		28/66/70	20/44/48	20/44/48

Performance		Model	CC-24R/Wa	CC-42R/WaS	CC-42R/HWaS
Refrigerant			R410a	R410a	R410a
Cooling Capacity	Btu/h		24000	42000	42000
Heating Capacity	Btu/h		26000	45000	45000
Power supply	Ph. V~, Hz		1,220.50	3,380.50	3,380.50
Rated Cooling Power Input	W		2750	4320	3900
Rated Heating Power Input	W		2700	4420	3900
Rated Cooling Operating Current	A		12.8	7.4	6.0
Rated Heating Operating Current	A		12.5	7.5	6.0
Air Flow Volume(indoor)	m³/h		1200	1750	1750
Noise Level (dB(A))	Indoor		48	52	52
	Outdoor		60	60	60
Net Dimensions W×D×H	Inside (mm)		950×950×305	950×950×365	950×950×365
	Outside (mm)		950×310×745	1000×410×1157	1000×410×1157
	Indoor/Outdoor		39/62	44/103	44/113
Packing Dimensions W×D×H	Indoor (mm)		900×900×305	905×915×370	905×915×370
	Panel (mm)		1045×1015×170	1045×1015×175	1045×1015×175
	Outdoor (mm)		1125×420×875	1100×480×1355	1100×480×1355
Gross Weight (kg)	Indoor/Outdoor		48/70	40(13)/118	40(13)/128
Applicable Area	m²		40-56	60-120	60-120
Loading Quantity (set)	20/40/40/HQ		28/66/70	20/44/48	20/44/48

- The data listed in the form only for reference, and the specific parameter shall refer to product nameplates.
- The applicable area of air conditioner is related to room orientation, insulation level, height of the building, the size and amount of the doors and windows, so that the applicable area is just for reference.
- Chulian reserves the right to change the product design, specifications, and parameters. There is no specific notice if there appears any adjustment, please refer to product specifications and product nameplates.



Duct Air Conditioners

### High efficient compressor

Chunlian duct air conditioner adopts high efficient compressor to increase the efficiency of refrigeration, the efficiency is 5% more than the ordinary compressor.



### Various control method

Chunlian duct air conditioner provides two kinds of control mode including remote control, wire control, allowing you to easily control the operation of the unit.



### Automatic fault diagnosis

The intelligent automatic fault diagnosis function enables the unit to detect the running status by itself so that the maintenance can be carried out in time.



### Finite element analysis technology

By application of the finite element analysis technology and air flow field stimulation technology, noise from vibration of the compressor and other moving parts is decreased a lot

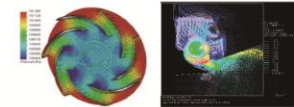

### High-density air filters

The high density air filter is made by high density organic fibres, which removes dust up to 78.6%, better than the most ordinary filters. The filter keeps the inside of the unit cleaner and then translates into cleaner air.

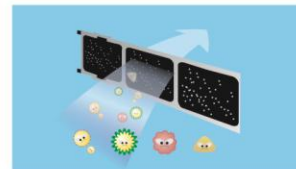

### Healthy new fresh air technology

The air conditioning can supply fresh air through the network management and eliminate indoor dirty air. The effect is quickly and thoroughly and the air can keep pure and fresh.





### Advanced Intelligent Centralized Control System

1. Perfect monitor and control function can monitor the operating situation of the units dynamically.
2. The number of network control can reach to 256 outdoor units, and the distance of centralized control signal can be 1000 meters away.
3. The outdoor units are built in high reliability communication modules. No need of external communication modules, which can facilitate the installation and maintenance.
4. 232485 photoelectric converter provides high anti-interference.
5. Enhanced type 485 communication chip with lightning protection device ensures that the whole units can work under various conditions.
6. One system can manage 16 groups of indoor units. Group installation enables all the air conditioners to open and close or modify parameters more conveniently.
7. The computer group control system can set to open or close the system timely and control the temperature freely according to customers' requirements.
8. The whole system is connected by a communication bus to remotely monitor the running status or operate all the units by computer. Each room is also installed remote control or line control to meet the requirement and control of individualized environments.

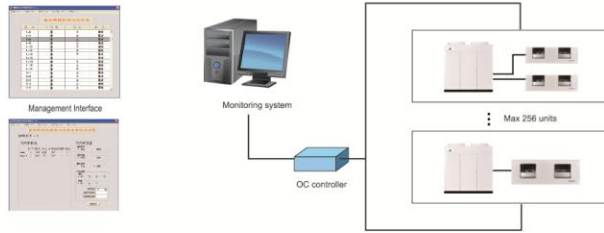

### Multi Module Combination

Chunlan module duct air conditioner units with flexible combination can achieve the combination of 256 units at most. It can realize arbitrary combination from 20 HP to 5120 HP according to the building load demand, providing the best flexible and economic environmental solution.



### High efficiency oil balance technology

**Oil return by vapor liquid separator**  
Accurate and unique oil return hole design, guaranteeing the compressor to realize stable and effective oil return. Besides, large capacity design can guarantee more cold media storage for the large system.

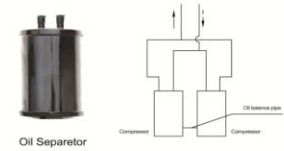

**Oil balance between compressors**  
There is an oil balance pipe in the compressor to realize the oil balance between compressors through the interaction of the compressor and the system.

### Intelligent start technology

When more than two units start to work, the units will start by sequence, so as to reduce the impact on power grid.

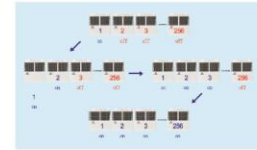

### Vector control electronic expansion valve

Immediately tracking the control target of the system, using vector control and electronic expansion valve to guarantee the efficient operation of the system, and accurately control indoor temperature, thus making you feel comfortable and pleasant.



Wide range subtle step adjusting technology by electronic expansion valve helps to adjust the refrigerant flow rate in a wide range but small step according to ambient temperature and user demand.

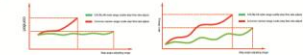

### Application Area

High static duct air conditioner: especially suitable for large supermarkets, shopping malls, workshop, libraries, leisure entertainments, hotels, and so on. It is quite suitable for large air conditioning engineering which has large space and long air-supplying distance.

Middle/low static duct air conditioner: it is widely used in small stores, hotels, restaurants, cafes, offices, conference rooms, etc., especially suitable for small commercial and civil building air conditioning engineering.





CDL-09R/Cd-4  
CDL-12R/Cd-4  
CDL-18R/Cd-4  
CDL-24R/Cd-4



CDH-42R/AS  
CDH-42R/AdS  
CDH-42R/AWaS



CDM-42R/AS  
CDM-42R/AdS  
CDM-42R/AWaS



CDH-60R/-S  
CDH-60R/dS  
CDH-60R/WadS



CDHM-170R(Q)FdS



CDH-170R(Q)dS



CDH-96R/-S  
CDH-96R/dS  
CDH-96R/WadS



CDHM-200R(Q)FdS



CDH-200R(Q)dS

Performance	Model	CDL-09R/Cd-4	CDL-09R/Cd-2	CDL-12R/Cd-4	CDL-12R/Cd-2
Refrigerant		R22	R22	R22	R22
Cooling Capacity	Btu/h	9000	9000	12000	12000
Heating Capacity	Btu/h	9000(2900)	9000(2900)	12000(4100)	12000(4100)
Power Supply	PH, V, Hz	1, 220, 50	1, 220, 50	1, 220, 50	1, 220, 50
Rated Cooling Power Input	W	1050	890	1480	1280
Rated Heating Power Input	W	1050(850)	795(850)	1460(1200)	1280(1200)
Rated Cooling Operating Input	A	4.8	4.1	6.8	5.9
Rated Heating Operating Input	A	4.8(4.0)	3.6(4.0)	6.7(5.5)	5.9(5.5)
Air Flow Volume (indoor unit)	m <sup>3</sup> /h	420	420	600	600
Noise Level (dB(A))					
	Inside	28-36	28-36	31-39	31-39
	Outside	50	50	52	52
Net Dimensions WxDxH					
	Indoor(mm)	888X466X234	888X466X234	888X466X234	888X466X234
	Outdoor(mm)	650X250X506	650X250X506	760X259X537	760X259X537
Net Weight (kg)	Indoor/Outdoor	24/28	25/28	26/35	26/35
Packing Dimensions WxDxH					
	Indoor(mm)	930X510X293	930X510X293	930X510X293	930X510X293
	Outdoor(mm)	775X345X545	775X345X545	885X346X592	885X346X592
Gross Weight (kg)	Indoor/Outdoor	26/33	27/33	28/40	28/40
Pipe Size (inch)					
	Liquid Pipe	1/4"	1/4"	1/4"	1/4"
	Gas Pipe	3/8"	3/8"	1/2"	1/2"
Applicable Area	m <sup>2</sup>	12-17	12-17	16-25	16-25
Loading Quantity (sets)		20/40/40HQ	95/205/235	85/180/205	85/180/205

Performance	Model	CDL-18R/Cd-4	CDL-18R/Cd-2	CDL-24R/Cd-4	CDL-24R/Cd-2
Refrigerant		R22	R22	R22	R22
Cooling Capacity	Btu/h	18000	18000	24000	24000
Heating Capacity	Btu/h	18000(5100)	18000(5100)	24000(7850)	24000(7850)
Power Supply	PH, V, Hz	1, 220, 50	1, 220, 50	1, 220, 50	1, 220, 50
Rated Cooling Power Input	W	2100	1760	2500	2500
Rated Heating Power Input	W	2000(1500)	1620(1500)	2920(2300)	2300(2300)
Rated Cooling Operating Input	A	9.6	8.0	13.6	11.7
Rated Heating Operating Input	A	9.2(6.8)	7.4(6.8)	13.4(10.5)	10.8(10.5)
Air Flow Volume (indoor unit)	m <sup>3</sup> /h	800	800	1500	1500
Noise Level (dB(A))					
	Inside	35-43	35-43	38-46	38-46
	Outside	54	54	58	58
Net Dimensions WxDxH					
	Indoor(mm)	1088X466X234	1088X466X234	1260X555X226	1260X555X226
	Outdoor(mm)	823X275X846	823X275X846	950X310X745	950X310X745
Net Weight (kg)	Indoor/Outdoor	28/48	28/48	46/85	46/85
Packing Dimensions WxDxH					
	Indoor(mm)	1130X510X293	1130X510X293	1385X595X255	1385X595X255
	Outdoor(mm)	965X380X880	965X380X880	1125X420X875	1125X420X875
Gross Weight (kg)	Indoor/Outdoor	30/55	30/55	48/75	50/75
Pipe Size (inch)					
	Liquid Pipe	1/4"	1/4"	3/8"	3/8"
	Gas Pipe	1/2"	1/2"	5/8"	5/8"
Applicable Area	m <sup>2</sup>	20-35	20-35	30-50	30-50
Loading Quantity (sets)		20/40/40HQ	65/140/160	48/105/125	48/105/125

Remark: 1. Cooling condition: Indoor dry-bulb temperature 27°C, wet-bulb temperature 19°C, Outdoor dry-bulb temperature 35°C, wet-bulb temperature 24°C.  
2. Heating condition: Indoor dry-bulb temperature 20°C, Outdoor dry-bulb temperature 7°C, wet bulb temperature 6°C.

- The data listed in the form only for reference, and the specific parameter shall refer to product nameplates.
- The applicable area of air conditioner is related to room orientation, insulation level, height of the building, the size and amount of the doors and windows, so that the applicable area is just for reference.
- Chunlian reserves the right to change the product design, specifications, and parameters. There is no specific notice if there appears any adjustment, please refer to product specifications and product nameplates.

Performance	Model	CDM-42R(A)d/S	CDM-42R(A)W/s	CDH-42R(A)d/S	CDH-42R(A)W/s
Refrigerant		R22	R410a	R22	R410a
Cooling Capacity	Btu/h	42000	42000	42000	42000
Heating Capacity	Btu/h	45000(8900)	45000	45000(10200)	45000
Power Supply	PH, V, Hz	3, 380, 50	3, 380, 50	3, 380, 50	3, 380, 50
Rated Cooling Power Input	W	4900	4000	4900	4000
Rated Heating Power Input	W	4400(2600)	3800	4650(3000)	3800
Rated Cooling Operating Input	A	8.4	6.8	8.6	6.8
Rated Heating Operating Input	A	7.8(12.0)	6.7	8.2(5.0)	6.7
Air Flow Volume (indoor unit)	m <sup>3</sup> /h	1900	1900	2100	2100
Noise Level (dB(A))	Inside	42-50	42-50	49-55	49-55
	Outside	60	60	60	60
Net Dimensions WxDxH	Indoor(mm)	1150X750X285	1150X750X285	934X618X402	934X618X402
	Outdoor(mm)	1000X410X1157	1000X410X1157	1000X410X1157	1000X410X1157
Net Weight (kg)	Indoor/Outdoor	52(54)/103	52(113)	42(49)/103	42(113)
Packing Dimensions WxDxH	Indoor(mm)	1255X799X315	1255X799X315	1030X645X430	1030X645X430
	Outdoor(mm)	1100X480X1355	1100X480X1355	1100X480X1355	1100X480X1355
Gross Weight (kg)	Indoor/Outdoor	58(60)/118	58(128)	50(61)/118	50(128)
Pipe Size (inch)	Liquid Pipe	1/2"	1/2"	1/2"	1/2"
	Gas Pipe	3/4"	3/4"	3/4"	3/4"
Applicable Area	m <sup>2</sup>	60-120	60-120	60-120	60-120
Loading Quantity (sets)		20/40/40/HQ	24/48/48	24/48/48	24/48/48

Performance	Model	CDH-60R-S	CDH-60Rd/S	CDH-60R/WdS
Refrigerant		R22	R22	R410a
Cooling Capacity	Btu/h	60000	60000	60000
Heating Capacity	Btu/h	63000	63000(20500)	63000
Power Supply	PH, V, Hz	3, 380, 50	3, 380, 50	3, 380, 50
Rated Cooling Power Input	W	7000	7000	6100
Rated Heating Power Input	W	6200	6200(6000)	6000
Rated Cooling Operating Input	A	11.7	11.7	10.2
Rated Heating Operating Input	A	10.4	10.4(10.0)	10.0
Air Flow Volume (indoor unit)	m <sup>3</sup> /h	3100	3100	3100
Noise Level (dB(A))	Inside	50-56	50-56	50-56
	Outside	61	61	61
Net Dimensions WxDxH	Indoor(mm)	1377X619X402	1377X619X402	1377X619X402
	Outdoor(mm)	1020X450X1357	1020X450X1357	1020X450X1357
Net Weight (kg)	Indoor/Outdoor	65/150	79/150	65/156
Packing Dimensions WxDxH	Indoor(mm)	1510X645X430	1510X645X430	1510X645X430
	Outdoor(mm)	1140X500X1500	1140X500X1500	1140X500X1500
Gross Weight (kg)	Indoor/Outdoor	77/175	99/175	99/181
Pipe Size (inch)	Liquid Pipe	1/2"	1/2"	1/2"
	Gas Pipe	7/8"	7/8"	7/8"
Applicable Area	m <sup>2</sup>	85-170	85-170	85-170
Loading Quantity (sets)		20/40/40/HQ	22/46/46	22/46/46

Remark: 1. Cooling condition: Indoor dry-bulb temperature 27°C, wet-bulb temperature 19°C, Outdoor dry-bulb temperature 35°C, wet-bulb temperature 24°C  
 2. Heating condition: Indoor dry-bulb temperature 20°C, Outdoor dry-bulb temperature 7°C, wet bulb temperature 6°C

- The data listed in the form only for reference, and the specific parameter shall refer to product nameplates.
- The applicable area of air conditioner is related to room orientation, insulation level, height of the building, the size and amount of the doors and windows, so that the applicable area is just for reference.
- Chunlian reserves the right to change the product design, specifications, and parameters. There is no specific notice if there appears any adjustment, please refer to product specifications and product nameplates.

Performance	Model	CDH-96R-S	CDH-96Rd/S	CDH-96R/WdS
Refrigerant		R22	R22	R410a
Cooling Capacity	Btu/h	96000	96000	96000
Heating Capacity	Btu/h	100000	100000(30700)	100000
Power Supply	PH, V, Hz	3, 380, 50	3, 380, 50	3, 380, 50
Rated Cooling Power Input	W	11300	11300	10000
Rated Heating Power Input	W	9500	9500(9000)	9200
Rated Cooling Operating Input	A	18.9	18.9	16.8
Rated Heating Operating Input	A	16.4	16.4(13.6)	15.9
Air Flow Volume (indoor unit)	m <sup>3</sup> /h	4500	4500	4500
Noise Level (dB(A))	Inside	55-61	55-61	55-61
	Outside	63	63	63
Net Dimensions WxDxH	Indoor(mm)	1870X619X402	1870X619X402	1870X619X402
	Outdoor(mm)	980X360X1061	980X360X1061	980X360X1061
Net Weight (kg)	Indoor/Outdoor	85/182	99/182	85/192
Packing Dimensions WxDxH	Indoor(mm)	2010X665X430	2010X665X430	2010X665X430
	Outdoor(mm)	1026X1026X1215	1026X1026X1215	1026X1026X1215
Gross Weight (kg)	Indoor/Outdoor	100/212	122/212	100/222
Pipe Size (inch)	Liquid Pipe	5/8"	5/8"	5/8"
	Gas Pipe	9/8"	9/8"	9/8"
Applicable Area	m <sup>2</sup>	140-280	140-280	140-280
Loading Quantity (sets)		20/40/40/HQ	10/22/32	10/22/30

Performance	Model	CDH-170R(Q)d/S	CDH-200R(Q)d/S	CDHM-170R(Q)F/dS	CDHM-200R(Q)F/dS
Refrigerant		R22	R22	R22	R22
Cooling Capacity	Btu/h	17000	20000	8500X2	10200X2
Heating Capacity	Btu/h	17800(34100)	21000(34100)	8900X2(34100)	10570X2(9000)
Power Supply	PH, V, Hz	3, 380, 50	3, 380, 50	3, 380, 50	3, 380, 50
Rated Cooling Power Input	W	21000	24200	10500X2	10500X2
Rated Heating Power Input	W	2000(10000)	2400(15000)	10000X2	12000(9000)
Rated Cooling Operating Input	A	35	40.5	17.2X2	20X2
Rated Heating Operating Input	A	34.5(17.0)	40.3(25.5)	17.0X2	20X2(17.0)
Air Flow Volume (indoor unit)	m <sup>3</sup> /h	9000	10000	4500X2	5000X2
Noise Level (dB(A))	Inside	60	71	60	63
	Outside	65	74	65	74
Net Dimensions WxDxH	Indoor(mm)	1800X818X800	1800X850X860	(1800X618X400)X2	(1800X618X400)X2
	Outdoor(mm)	1920X960X2000	1920X960X2000	1920X960X2000	1920X960X2000
Net Weight (kg)	Indoor/Outdoor	160/580	208/580	85X2/518	85X2/580
Packing Dimensions WxDxH	Indoor(mm)	2010X665X430	2010X665X430	(2010X665X430)X2	(2010X665X430)X2
	Outdoor(mm)	2074X1114X2189	2074X1114X2189	2074X1114X2189	2074X1114X2189
Gross Weight (kg)	Indoor/Outdoor	200/568	228/640	100X2/578	100X2/640
Pipe Size (inch)	Liquid Pipe	1"	1"	5/8"	5/8"
	Gas Pipe	1 1/8"	1 1/8"	9/8"	9/8"
Applicable Area	m <sup>2</sup>	280-500	280-500	280-500	280-500
Loading Quantity (sets)		20/40/40/HQ	4/8/8	4/8/8	4/8/8

Remark: 1. Cooling condition: Indoor dry-bulb temperature 27°C, wet-bulb temperature 19°C, Outdoor dry-bulb temperature 35°C, wet-bulb temperature 24°C  
 2. Heating condition: Indoor dry-bulb temperature 20°C, Outdoor dry-bulb temperature 7°C, wet bulb temperature 6°C

- The data listed in the form only for reference, and the specific parameter shall refer to product nameplates.
- The applicable area of air conditioner is related to room orientation, insulation level, height of the building, the size and amount of the doors and windows, so that the applicable area is just for reference.
- Chunlian reserves the right to change the product design, specifications, and parameters. There is no specific notice if there appears any adjustment, please refer to product specifications and product nameplates.



Multi-Connected DC Inverter Air Conditioning System

Features

- World leading modularization inverter multi-connected air-conditioning system, for seamless connecting
- World leading oil separation/return technology, break the world record of VRV connection quantity
- Unique digitalize self adaptive intelligent control system, higher reliability and efficiency, and lower operational cost
- Super high efficient, and energy saving
- Advanced multisystem control system
- Accurate Temperature Control
- Various indoor terminals selection
- Comprehensive protection function



Three proprietary technology

- Advanced modularized inverter multi-connection technology to realize seamless connection
- Advanced oil separate and oil return technology. Breaking the world record of the VRV units connection quantity
  1. Proprietary oil return software , ensure sufficient oil available
  2. Proprietary oil throw technology, protect the compressor from excessive oil
  3. Specially designed efficient oil/gas separator, ensure the enough lubricant oil in the system, prevent slugging and running without enough oil
- Unique digitalized self-adaptive intelligent control system. Reliability, efficiency and profitability are great improved

New generation high pressure cavity DC inverter scroll compressor

- High rigidity compression shell
- Exclusive high-precision asymmetric vortex disk
- Internal oil separation mechanism
- High performance neodymium magnetic material rotor
- Magnetic resistance type DC motor
- The compressor automatically oil-throw
- Compressor oil volume control device



The new generation DC inverter compressor with 4 optimized protection functions, which ensures compressor operation more smoothly and efficiently.

- Demagnetization protection
- Anti frost protection (
- Protection against high temperature \
- Over-current protection

The advantages of high pressure cavity DC inverter scroll compressor

- The stability of high pressure cavity compressor is better than low pressure cavity one
- The capacity rate of high pressure cavity compressor is higher
- The low temperature heating performance of high pressure cavity compressor is better
- The high pressure cavity compressor exhausts noise is lower
- Asymmetric vortex disk structure design improves the operation efficiency

Asymmetric vortex disk structure design improves the operation efficiency.



### Compressor parallel connection energy-saving control technology

Compressor parallel connection technology  
 Several compressors share a set of condenser, when one or more stop work, it equals to the heat transfer area of the condenser increases exponentially  
 Condenser adjustment technology  
 Since the DC invert compressor's energy efficiency is the highest under specific partial load, the condenser use electronic expansion valve control design, according to the unit load, adjusting the electronic expansion valve, enable the compressor to maintain efficient running state under partial load

### HVAC industry's leading invert control technology

PAM180°DC invert control technology with own patent.

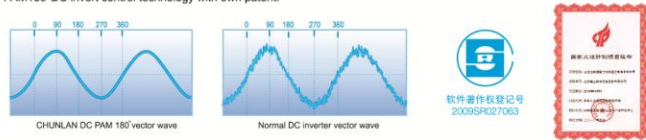

### Chunlan high efficiency inner grooved copper tube/aluminum fin

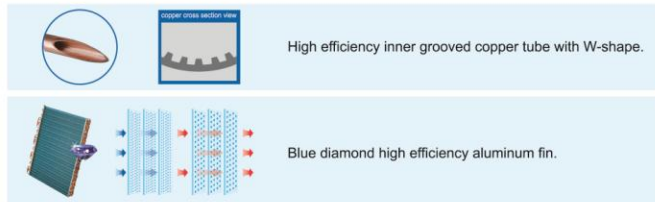

### Advanced refrigerant control technology



### Rotation Technology

Intelligent rotation running technology, auto rotation setting decides the start priority of certain outdoor unit module and compressor. Average distribute the working time between every outdoor unit module, the module's compressor and different module's compressor, which can effectively increase the working life of the compressor.

#### Rotation Technology of the outdoor unit module

Module compressor's rotation technology combine with the outdoor unit module's rotation technology, then the compressor' rotation between the modules can be achieved.

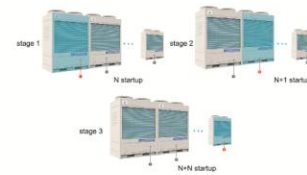

#### Rotation Technology of single module

Module compressor's rotation technology, then the compressor's rotation within the module can be achieved.

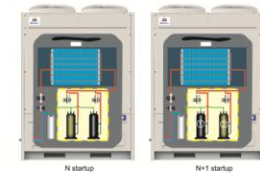

### Suppress Electromagnetic interference

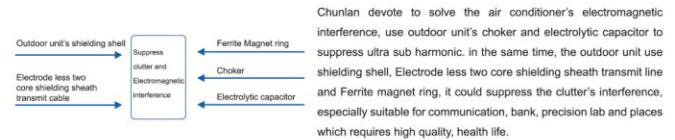

### The refrigerant pressure' detection technology

With the refrigerant pressure' detection technology, the system works in stable and efficient condition.  
 The quick and exactly detection on the system's refrigerant condition is the guarantee of the system efficient work. Chunlan CDMVIII Inverter Multi-Connected unit not only use the temperature sensor to detect the unit working information, also it can quickly, entirely, accurately detect the refrigerant state by using high pressure and low pressure sensor. Self adoption of the system refrigerant's requirement, make the system working in stable and higher efficient condition.



Comprehensive protection function



- 1 Exhaust temperature protection
- 2 Driver module protection function
- 3 Default phase reverse phase protection function
- 4 Refrigerant shortage protection
- 5 Compressor running current protection

Fault memory function



Wide running condition for the outdoor unit, flexibly suit for various temperature conditions

Wider running temperature range for the outdoor unit, which is suitable for different temperature conditions. Even under very bad temperature condition, the system can run stably

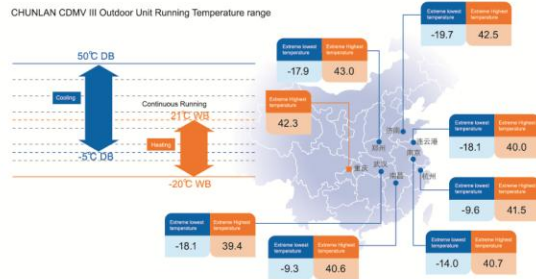

Wide voltage design, coping with the power consumption peak

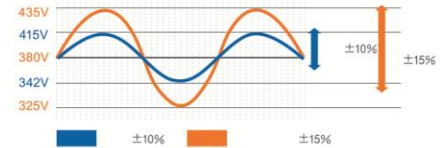

Wide system volume, Limitless volume combination

By modularized design, system volume increases progressively with 2HP. No gaps exist between the units. Seamless connection is really realized. Units connected in parallel can be more than 10pcs and maximum capacity can be more than 200HP.

Household VRV system



Modularized VRV system



There is no capacity limit for the unit connection. Parallel connected system capacity can be more than 200HP

Pipe length reaches 110m without reduction of heating capacity

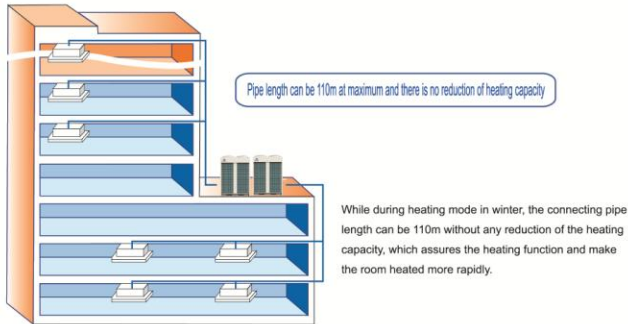

Application Area: school, home, restaurant, supermarket, hotel and other area.



Multi-connected Air-conditioning System

Ultra long refrigerant pipe, free design and construction

Maximal single pipe length:

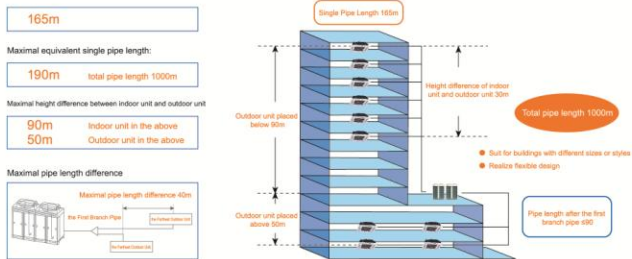

Notes:

1. Pipe length after the first branch pipe more than 40m should meet certain conditions. Please consult Chunlan Engineers for details.
2. Applicable for 350 or above models.
3. 250/300 model: total pipe length is 510m; maximal single pipe length is 120m; maximal equivalent single pipe length is 140m; maximal height difference of between indoor units is 15m; maximal height difference between indoor unit and outdoor unit is 50m.

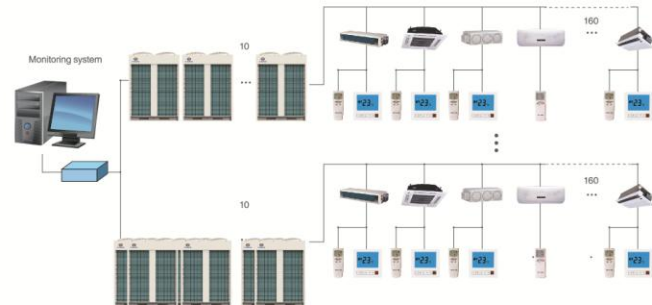







high static pressure duct type

Model Performance	Cooling Capacity (kW)	Heating Capacity (kW)	Air Flow (m <sup>3</sup> /h)	Noise Level (dB(A))	Static Pressure (Pa)	Power Supply	Rated Power Input (W)		Pipe Size (mm)			Water Pipe Size (mm)			Dimension (mm)			Weight (kg)	Applicable Area (m <sup>2</sup> )
							Cooling	Heating	Gas	Liquid	W	D	H	W	D	H			
																	W		
CDMV-R129F3/BPWio	12	13	2200	42-50	80	220V-50Hz	450	450	19.05	9.52	22	934	618	400	42	60-120			
CDMV-R129F3/BPWio	12.5	14	2200	42-50	80	220V-50Hz	450	450	19.05	9.52	22	934	618	400	42	62-125			
CDMV-R170F3/BPWio	17	18	3100	44-52	80	220V-50Hz	800	800	22.23	12.7	22	1377	619	402	65	85-170			
CDMV-R260F3/BPWio	28	29	4500	48-56	80	220V-50Hz	1800	1800	28.58	15.88	22	1870	619	402	85	140-280			



one-way cassette type

Model Performance	Cooling Capacity (kW)	Heating Capacity (kW)	Air Flow (m <sup>3</sup> /h)	Noise Level (dB(A))	Static Pressure (Pa)	Power Supply	Rated Power Input (W)		Pipe Size (mm)			Water Pipe Size (mm)			Dimension (mm)			Weight (kg)	Applicable Area (m <sup>2</sup> )
							Cooling	Heating	Gas	Liquid	W	D	H	W	D	H			
																	W		
CDMV-R23G1/BPWio	2.3	2.5/0.85	450	26-35	0	220V-50Hz	46	46	9.52	6.35	22	850	400	235	23	10-24			
CDMV-R25G1/BPWio	2.5	2.7/0.85	450	26-35	0	220V-50Hz	46	46	9.52	6.35	22	850	400	235	23	12-25			
CDMV-R28G1/BPWio	2.8	3.0/0.85	450	26-35	0	220V-50Hz	46	46	9.52	6.35	22	850	400	235	23	14-28			
CDMV-R32G1/BPWio	3.2	3.5/1.2	600	28-36	0	220V-50Hz	50	50	12.73	6.35	22	1200	655	198	23	16-32			
CDMV-R36G1/BPWio	3.5	3.9/1.2	600	28-36	0	220V-50Hz	50	50	12.7	6.35	22	1200	655	198	23	17-35			
CDMV-R43G1/BPWio	4.5	5.0/1.5	800	35-41	0	220V-50Hz	70	70	12.7	6.35	22	1200	655	198	35	22-45			
CDMV-R50G1/BPWio	5.0	5.6/1.5	800	35-41	0	220V-50Hz	70	70	12.7	6.35	22	1200	655	198	35	25-50			
CDMV-R56G1/BPWio	5.6	6.3/1.5	800	35-41	0	220V-50Hz	70	70	12.7	6.35	22	1200	655	198	35	85-55			



wall split type

Model Performance	Cooling Capacity (kW)	Heating Capacity (kW)	Air Flow (m <sup>3</sup> /h)	Noise Level (dB(A))	Power Supply	Rated Power Input (W)		Pipe Size (mm)			Water Pipe Size (mm)			Dimension (mm)			Weight (kg)	Applicable Area (m <sup>2</sup> )
						Cooling	Heating	Gas	Liquid	W	D	H	W	D	H			
																W		
CDMV-R23G/BPWio	2.3	2.5	450	32-37	220V-50Hz	30	30	9.52	6.35	16	780	201	274	9	10-24			
CDMV-R25G/BPWio	2.5	2.7	500	33-38	220V-50Hz	32	32	9.52	6.35	16	780	201	274	9.3	12-25			
CDMV-R28G/BPWio	2.8	3.1	500	34-39	220V-50Hz	35	35	9.52	6.35	16	780	201	274	9.3	14-28			
CDMV-R32G/BPWio	3.2	3.5	560	36-41	220V-50Hz	40	40	12.7	6.35	16	780	201	274	9.3	16-32			
CDMV-R36G/BPWio	3.5	3.8	640	37-42	220V-50Hz	45	45	12.7	6.35	16	860	201	274	10.8	17-35			
CDMV-R43G/BPWio	4.5	5.0	800	40-45	220V-50Hz	50	50	12.7	6.35	16	860	201	274	10.8	22-45			
CDMV-R50G/BPWio	5.0	5.5	860	41-46	220V-50Hz	53	53	12.7	6.35	16	860	201	274	10.8	25-50			

- The data listed in the form only for reference, and the specific parameter shall refer to product nameplates.
- The applicable area of air conditioner is related to room orientation, insulation level, height of the building, the size and amount of the doors and windows, so that the applicable area is just for reference.
- Chunlian reserves the right to change the product design, specifications, and parameters. There is no specific notice if there appears any adjustment, please refer to product specifications and product nameplates.



middle static pressure duct type

Model Performance	Cooling Capacity (kW)	Heating Capacity (kW)	Air Flow (m <sup>3</sup> /h)	Noise Level (dB(A))	Static Pressure (Pa)	Power Supply	Rated Power Input (W)		Pipe Size (mm)			Water Pipe Size (mm)			Dimension (mm)			Weight (kg)	Applicable Area (m <sup>2</sup> )
							Cooling	Heating	Gas	Liquid	W	D	H	W	D	H			
																	W		
CDMV-R109F2/BPWio	10	11	1900	42-50	50	220V-50Hz	300	300	19.05	9.52	16	1150	750	285	52	50-100			
CDMV-R129F2/BPWio	12	13	1900	42-50	50	220V-50Hz	300	300	19.05	9.52	16	1150	750	285	52	57-125			



four-way cassette type

Model Performance	Cooling Capacity (kW)	Heating Capacity (kW)	Air Flow (m <sup>3</sup> /h)	Noise Level (dB(A))	Power Supply	Rated Power Input (W)		Pipe Size (mm)			Water Pipe Size (mm)			Dimension (mm)			Weight (kg)	Applicable Area (m <sup>2</sup> )
						Cooling	Heating	Gas	Liquid	W	D	H	W	D	H			
																W		
CDMV-R50G4/BPWio	5	5	800	40-45	220V-50Hz	90	90	12.7	6.35	22	950	950	305	30	8	25-50		
CDMV-R60G4/BPWio	6	6	900	40-45	220V-50Hz	90	90	12.7	6.35	22	950	950	305	30	8	30-60		
CDMV-R66G4/BPWio	6.5	7.1	1200	41-46	220V-50Hz	100	100	15.88	9.52	22	950	950	305	39	8	32-65		
CDMV-R70G4/BPWio	7	7.8	1200	41-46	220V-50Hz	100	100	15.88	9.52	22	950	950	305	39	8	35-70		
CDMV-R75G4/BPWio	7.5	8.3	1200	41-46	220V-50Hz	100	100	15.88	9.52	22	950	950	305	39	8	37-75		
CDMV-R90G4/BPWio	9	10	1600	43-48	220V-50Hz	160	160	19.05	9.52	22	950	950	365	44	8	45-90		
CDMV-R95G4/BPWio	9.5	10.5	1600	43-48	220V-50Hz	160	160	19.05	9.52	22	950	950	365	44	8	47-95		
CDMV-R100G4/BPWio	10	11	1600	43-48	220V-50Hz	160	160	19.05	9.52	22	950	950	365	44	8	50-100		
CDMV-R120G4/BPWio	12	13	1750	45-50	220V-50Hz	180	180	19.05	9.52	22	950	950	365	44	8	60-120		
CDMV-R125G4/BPWio	12.5	14	1750	45-50	220V-50Hz	180	180	19.05	9.52	22	950	950	365	44	8	62-125		



floor standing type

Model Performance	Cooling Capacity (kW)	Heating Capacity (kW)	Air Flow (m <sup>3</sup> /h)	Noise Level (dB(A))	Static Pressure (Pa)	Power Supply	Rated Power Input (W)		Pipe Size (mm)			Water Pipe Size (mm)			Dimension (mm)			Weight (kg)	Applicable Area (m <sup>2</sup> )
							Cooling	Heating	Gas	Liquid	W	D	H	W	D	H			
																	W		
CDMV-R55L/BPWio	5	5.6/1.6	800	35-43	0	220V-50Hz	62	62	12.7	6.35	26.8	500	295	1760	41	25-50			
CDMV-R56L/BPWio	5.6	6.3/1.6	800	35-43	0	220V-50Hz	62	62	12.7	6.35	26.8	500	295	1760	41	28-55			
CDMV-R67L/BPWio	7.1	7.5/2200	1500	38-46	0	220V-50Hz	116	116	15.88	9.52	26.8	500	295	1760	43	35-70			
CDMV-R68L/BPWio	8	8.8/2200	1500	38-46	0	220V-50Hz	160	160	15.88	9.52	26.8	500	295	1760	43	40-80			
CDMV-R69L/BPWio	9	9.5/2200	2000	40-48	0	220V-50Hz	200	200	19.05	9.52	26.8	690	425	1915	46	45-90			
CDMV-R810L/BPWio	10	10.5/2200	2000	40-48	0	220V-50Hz	200	200	19.05	9.52	26.8	690	425	1915	48	50-100			
CDMV-R120L/BPWio	12	13/3000	2200	42-50	0	220V-50Hz	450	450	19.05	9.52	26.8	690	425	1915	50	60-120			

- The data listed in the form only for reference, and the specific parameter shall refer to product nameplates.
- The applicable area of air conditioner is related to room orientation, insulation level, height of the building, the size and amount of the doors and windows, so that the applicable area is just for reference.
- Chunlian reserves the right to change the product design, specifications, and parameters. There is no specific notice if there appears any adjustment, please refer to product specifications and product nameplates.



Modular Air Cooled (Heated) Water Chiller

### Healthy fresh air technology

Unit connects directly to the fan coil to supply air, uniform distribution of cold and heat energy, with the new wind system it can greatly improve indoor air quality to make you enjoy good feeling as in star-rated hotel.

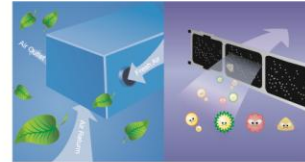

### Efficient plate heat exchanger

Adopting the efficient braze plate heat exchanger, not only improve the energy efficiency coefficient, but also reduce the weight.

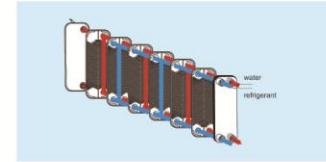

### High reliability components

Adhering to Chunlan more than 50 years experience on design and manufacturing of refrigerating products, the simulation of air flow field, finite element analysis and the original core technology are widely used in Chunlan air cooled (heated) water chiller air conditioners, which are well performed with high reliability.



### Ultra-wide temperature regulation

In summer, the chilled water temperature can reach to 5 °C - 20 °C; in winter, the heating water can reach to 30 °C - 55 °C, which fully satisfy cooling and heating demand of all level users.

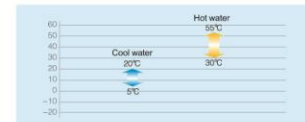

### Wide climate adaptability

Chunlan air cooled (heated) water chiller air conditioners can continually and reliably run in a wide temperature range (cooling: 10 to 52 °C; heating: -15 to 27 °C).



### Automatically adjusting power input

The system uses microcomputer control, automatically adjust the units' input or with drawl according to the power load, to make whole system in highly efficient operation, and protecting the power system .

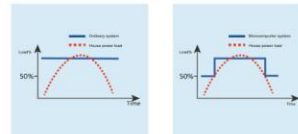

### Comfortable temperature regulation

The system uses water as the heat exchange medium, which makes small temperature difference between air temperature and room temperature, and provides gentle and comfortable wind. The temperature of the water can be regulated  $\pm 0.5$  °C ..



Advanced intelligent centralized control system

1. The control system is consisted of monitoring computer (optional), main controller and sub-controller.
2. Monitoring computer can monitor the operation of the units without being out of house. The master can be installed in the main electrical control box or in the control room to monitor and operate the unit, automatic run without attending and the rate of automatically opening and stopping one unit each time meets the changes in the load of the air conditioning system makes the unit run with the maximum efficiency in various state to save energy.
3. The sub-controller control one unit containing two independent cooling and heating fluorine systems.
4. The main controller and sub-controller adopt 485-way to communicate. Between the main controller and monitor computer, 485-232-way communication is adopted through communication converter module.
5. It is with remote control function, each system can control 256 modules at most through matching physical interface via RS485 communication protocol with building automation control function.

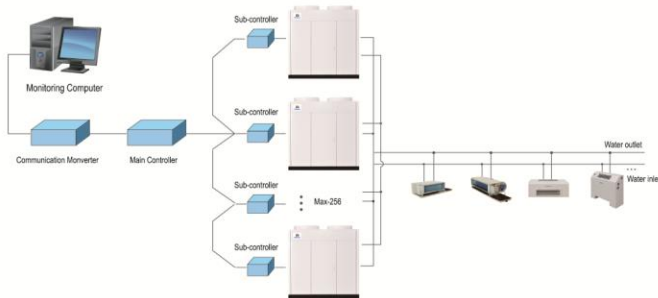

Flexibility combination

By its unique modularized combination style, Chunlan air cooled (heated) water chiller air conditioners can be combined freely and flexibly according to different environmental needs. The capacity range is from 100kW-12800kW.

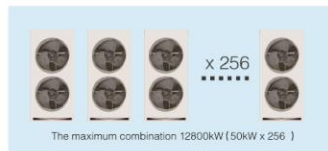

Any main control module design

In one combination, any unit can be run as the main control module, which be connected with monitoring computer, to coordinate each module operation in the combination and monitor the whole system operational state.



Alternate defrost technology

Since each unit module is an independent cooling system, the computer controls defrost of each unit module in winter makes defrost of each unit keep in alternate states to achieve a small range of water temperature fluctuations and the balance of the heating operation.

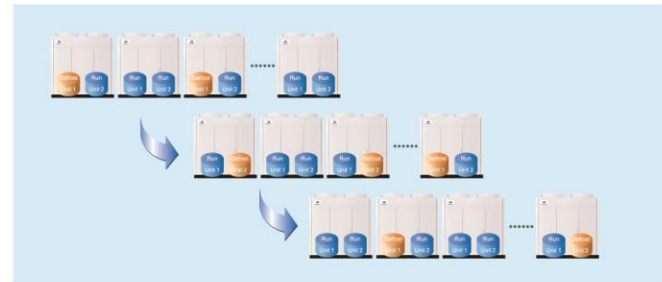

Alternative cycle duty design

In combination which compressor numbers more than or equal to 4 unit, the compressor that continuous works more than 24 hours will be stopped to standby; the compressor that stop more than 24 hours will automatically work, to realize the equal lifespan among the units in the combination

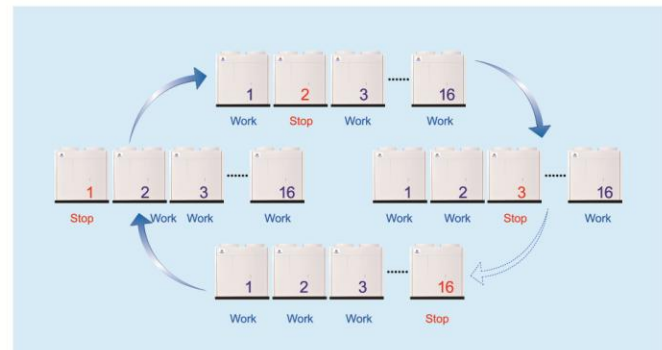



Performance	Model	CL-42R/S	CL-60R/AS	CL-96R/S
Refrigerant		R22	R22	R22
Cooling Capacity	Btu/h	42000	60000	96000
Heating Capacity	Btu/h	45000	63000	100000
Power Supply	PH, V, Hz	3, 380, 50	3, 380, 50	3, 380, 50
Rated Cooling Power Input	W	4590	5800	10800
Rated Heating Power Input	W	4450	6300	10400
Rated Cooling Operating Input	A	8.5	11.4	18.2
Rated Heating Operating Input	A	8.8	12.6	17.6
Noise Level	dB(A)	60	62	63
Net Dimensions WxDxH	mm	950X450X1157	950X450X1357	980X980X1061
Net Weight	kg	180	230	222
Packing Dimensions WxDxH	mm	1140X500X1300	1140X500X1500	1026X1026X1215
Gross Weight	kg	195	255	252
Applicable Area	m <sup>2</sup>	60-120	85-170	140-280

- The data listed in the form only for reference, and the specific parameter shall refer to product nameplates.
- The applicable area of air conditioner is related to room orientation, insulation level, height of the building, the size and amount of the doors and windows, so that the applicable area is just for reference.
- Chunlan reserves the right to change the product design, specifications, and parameters. There is no specific notice if there appears any adjustment, please refer to product specifications and product nameplates.

Model	LSQWRF60MB-E4							
Cooling Capacity	kw	60	130	190	240	300	60N (N<25E)	
	Kcal/h	51600	102000	154800	206400	258000	51600N	
Heating Capacity	kw	61	122	183	244	305	61N	
	Kcal/h	52460	104920	157380	209840	262300	52460N	
Power Input	kw	21	21x2	21x3	21x4	21x5	21N	
Power Supply		380V 3N~50Hz						
Compressor	Type	Hermetic Scroll Compressor						
Air Flow	m <sup>3</sup> /h	26000	52000	78000	104000	130000	26000N	
Water Flow	m <sup>3</sup> /h	10.3	20.6	30.9	41.2	51.5	10.3N	
Water Resistance	KPa	50	52.5	55	57.5	60	50±2.5 (N-I)	
Net Weight	kg	550	550x2	550x3	550x4	550x5	550N	
Refrigerant		R22						
Charging volume	kg	7.35x2	7.35x4	7.35x6	7.35x8	7.35x10	7.35xN	
Pipe Diameter and type		DN20 Flange connection						
Dimension	WxDxHmm	1400X960X1903(Single Modular)						
Ambient temperature	°C	-7~43						

Model	LSQWRF65M-E4							
Cooling Capacity	kw	65	130	195	260	325	65N (N<25E)	
	Kcal/h	55900	111800	167700	223600	279500	55900N	
Heating Capacity	kw	66	132	198	264	330	66N	
	Kcal/h	56760	113520	170280	227040	283800	56760N	
Power Input	kw	22.7	22.7x2	22.7x3	22.7x4	22.7x5	22.7N	
Power Supply		380V 3N~50Hz						
Compressor	Type	Hermetic Scroll Compressor						
Air Flow	m <sup>3</sup> /h	26000	52000	78000	104000	130000	26000N	
Water Flow	m <sup>3</sup> /h	11.2	22.4	33.6	44.8	56	11.2N	
Water Resistance	KPa	50	52.5	55	57.5	60	50±2.5 (N-I)	
Net Weight	kg	580	580x2	580x3	580x4	580x5	580N	
Refrigerant		R22						
Charging volume	kg	7.5x2	7.5x4	7.5x6	7.5x8	7.5x10	7.5xN	
Pipe Diameter and type		DN20 Flange connection						
Dimension	WxDxHmm	1600x960x1903(Single Modular)						
Ambient temperature	°C	-7~43						

Model	LSQWRF65M-E2							
Cooling Capacity	kw	65	130	195	260	325	65N (N<25E)	
	Kcal/h	55900	111800	167700	223600	279500	55900N	
Heating Capacity	kw	65	130	195	260	325	65N	
	Kcal/h	55900	111800	167700	223600	279500	55900N	
Power Input	kw	19.9	19.9x2	19.9x3	19.9x4	19.9x5	19.9N	
Power Supply		380V 3N~50Hz						
Compressor	Type	Hermetic Scroll Compressor						
Air Flow	m <sup>3</sup> /h	26000	52000	78000	104000	130000	26000N	
Water Flow	m <sup>3</sup> /h	11.2	22.4	33.6	44.8	56	11.2N	
Water Resistance	KPa	50	52.5	55	57.5	60	50±2.5 (N-I)	
Net Weight	kg	580	580x2	580x3	580x4	580x5	580N	
Refrigerant		R22						
Charging volume	kg	8.5x2	8.5x4	8.5x6	8.5x8	8.5x10	8.5xN	
Pipe Diameter and type		DN20 Flange connection						
Dimension	WxDxHmm	1600x960x1903(Single Modular)						
Ambient temperature	°C	-7~43						

Model		LSQWRF100M-E4					
Cooling Capacity	kW	100	200	300	400	500	1000N (N<=256)
	Kcal/h	86000	172000	258000	344000	430000	860000N
Heating Capacity	kW	100	200	300	400	500	1000N
	Kcal/h	86000	172000	258000	344000	430000	860000N
Power Input	kW	35	35x2	35x3	35x4	35x5	35xN
Power Supply		380V 3N~50Hz					
Compressor	Type	Hermetic Scroll Compressor					
Air Flow	m <sup>3</sup> /h	52000	104000	156000	208000	260000	520000N
Water Flow	m <sup>3</sup> /h	17.2	34.4	51.6	68.8	86	17.2xN
Water Resistance	KPa	70	72.5	75	77.5	80	70~2.5 (N-1)
Net Weight	kg	1180	1200x2	1200x3	1200x4	1200x5	1200xN
Refrigerant		R22					
Charging volume	kg	6.8x4	6.8x8	6.8x12	6.8x16	6.8x20	6.8xN
Pipe Diameter and type		DN65 Flange connection					
Dimension	WxDxHmm	1900x1600x1903(Single Modular)					
Ambient temperature	°C	-7~43					

Model		LSQWRF130M-E4					
Cooling Capacity	kW	130	260	390	520	650	1300N (N<=256)
	Kcal/h	111800	223600	335400	447200	559000	1118000N
Heating Capacity	kW	130	260	390	520	650	1300N
	Kcal/h	111800	223600	335400	447200	559000	1118000N
Power Input	kW	46	46x2	46x3	46x4	46x5	46xN
Power Supply		380V 3N~50Hz					
Compressor	Type	Hermetic Scroll Compressor					
Air Flow	m <sup>3</sup> /h	52000	104000	156000	208000	260000	520000N
Water Flow	m <sup>3</sup> /h	22.4	44.8	67.2	89.6	112	22.4xN
Water Resistance	KPa	70	72.5	75	77.5	80	70~2.5 (N-1)
Net Weight	kg	1200	1200x2	1200x3	1200x4	1200x5	1200xN
Refrigerant		R22					
Charging volume	kg	7x4	7x8	7x12	7x16	7x20	7xN
Pipe Diameter and type		DN65 Flange connection					
Dimension	WxDxHmm	1900x1600x1903(Single Modular)					
Ambient temperature	°C	-7~43					

Model		LSQWRF130M-E2					
Cooling Capacity	kW	130	260	390	520	650	1300N (N<=256)
	Kcal/h	111800	223600	335400	447200	559000	1118000N
Heating Capacity	kW	130	260	390	520	650	1300N
	Kcal/h	111800	223600	335400	447200	559000	1118000N
Power Input	kW	39.5	39.5x2	39.5x3	39.5x4	39.5x5	39.5xN
Power Supply		380V 3N~50Hz					
Compressor	Type	Hermetic Scroll Compressor					
Air Flow	m <sup>3</sup> /h	52000	104000	156000	208000	260000	520000N
Water Flow	m <sup>3</sup> /h	22.4	44.8	67.2	89.6	112	22.4xN
Water Resistance	KPa	70	72.5	75	77.5	80	70~2.5 (N-1)
Net Weight	kg	1200	1200x2	1200x3	1200x4	1200x5	1200xN
Refrigerant		R22					
Charging volume	kg	8.5x4	8.5x8	8.5x12	8.5x16	8.5x20	8.5xN
Pipe Diameter and type		DN65 Flange connection					
Dimension	WxDxHmm	1900x1600x1903(Single Modular)					
Ambient temperature	°C	-7~43					

Model		LSQWRF160MA-E4					
Cooling Capacity	kW	160	320	480	640	800	1600N (N<=256)
	Kcal/h	137600	275200	412800	550400	688000	1376000N
Heating Capacity	kW	160	320	480	640	800	1600N
	Kcal/h	137600	275200	412800	550400	688000	1376000N
Power Input	kW	55	55x2	55x3	55x4	55x5	55xN
Power Supply		380V 3N~50Hz					
Compressor	Type	Hermetic Scroll Compressor					
Air Flow	m <sup>3</sup> /h	72000	144000	216000	288000	360000	720000N
Water Flow	m <sup>3</sup> /h	27.5	55	82.5	110	137.5	27.5xN
Water Resistance	KPa	120	122.5	125	127.5	130	120~2.5 (N-1)
Net Weight	kg	1400	1400x2	1400x3	1400x4	1400x5	1400xN
Refrigerant		R22					
Charging volume	kg	21x2	21x4	21x6	21x8	21x10	21xN
Pipe Diameter and type		DN80 Flange connection					
Dimension	WxDxHmm	2000x1900x2290(Single Modular)					
Ambient temperature	°C	-7~43					

Model		LSQWRF65MDW					
Cooling Capacity	kW	65	130	195	260	325	650N (N<=256)
	Kcal/h	55900	111800	167700	223600	279500	559000N
Heating Capacity	kW	70	140	210	280	350	700N
	Kcal/h	60200	120400	180600	240800	301000	602000N
Power Input	kW	18.6	19.6x2	19.6x3	19.6x4	19.6x5	19.6xN
Power Supply		380V 3N~50Hz					
Compressor	Type	Hermetic Scroll Compressor					
Air Flow	m <sup>3</sup> /h	26000	52000	78000	104000	130000	260000N
Water Flow	m <sup>3</sup> /h	11.2	22.4	33.6	44.8	56	11.2xN
Water Resistance	KPa	50	52.5	55	57.5	60	50~2.5 (N-1)
Net Weight	kg	580	580x2	580x3	580x4	580x5	580xN
Refrigerant		R22					
Charging volume	kg	8.5x2	8.5x4	8.5x6	8.5x8	8.5x10	8.5xN
Pipe Diameter and type		DN65 Flange connection					
Dimension	WxDxHmm	1600x960x1903(Single Modular)					
Ambient temperature	°C	-20~43					

Model		LSQWRF130MDW					
Cooling Capacity	kW	130	260	390	520	650	1300N (N<=256)
	Kcal/h	111800	223600	335400	447200	559000	1118000N
Heating Capacity	kW	130	260	390	520	650	1300N
	Kcal/h	111800	223600	335400	447200	559000	1118000N
Power Input	kW	39.5	39.5x2	39.5x3	39.5x4	39.5x5	39.5xN
Power Supply		380V 3N~50Hz					
Compressor	Type	Hermetic Scroll Compressor					
Air Flow	m <sup>3</sup> /h	52000	104000	156000	208000	260000	520000N
Water Flow	m <sup>3</sup> /h	22.4	44.8	67.2	89.6	112	22.4xN
Water Resistance	KPa	70	72.5	75	77.5	80	70~2.5 (N-1)
Net Weight	kg	1200	1200x2	1200x3	1200x4	1200x5	1200xN
Refrigerant		R22					
Charging volume	kg	8.5x4	8.5x8	8.5x12	8.5x16	8.5x20	8.5xN
Pipe Diameter and type		DN65 Flange connection					
Dimension	WxDxHmm	1900x1600x1903(Single Modular)					
Ambient temperature	°C	-20~43					



Water Cooled Screw Chiller

### Advanced Screw Compressor

#### F-Series(Single-Screw Compressor)

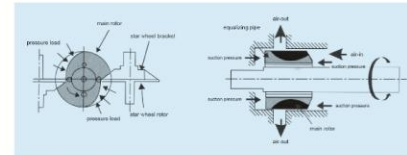
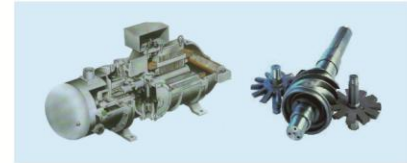

The overall design is quite compact, with the main rotor, the star wheel as the main moving parts, the f compressor has low possibility of downtime, high reliability and is very easy to maintain; Symmetrical compression process and balanced radial and axial load-carrying capability greatly reduce the bearing wear and load;



Steady exhaust and engaging wheels structure avoid sine wave. With Steady balanced operation and tiny vibration, the unit noise is decreased about 8db.

### Multi units combination, wide application range

Chunlian screw type chiller has powerful combination function. The quantity can be freely combined to realize specific cooling capacity. In this way the different space requirement can be met, and best environment solution can be provided to the customer.

 400F unit, 2 units are combined Cooling capacity 800kW   Heating capacity 830kW	 400F/600F/1600F unit, 3 units are combined Cooling capacity 3800kW   Heating capacity 3270kW	 1600F unit, 32 units are combined Cooling capacity 51200kW   Heating capacity 60800kW
 210K unit, 2 units are combined Cooling capacity 420kW   Heating capacity 430kW	 210K/400K/700K unit, 3 units are combined Cooling capacity 1400kW   Heating capacity 1580kW	 700K unit, 32 units are combined Cooling capacity 22400kW   Heating capacity 29700kW

**K-Series(Double-Screw Compressor)**

World-famous brand semi-hermetic double-screw compressor is used. Its advanced 5-6 asymmetrical gear is energy saving. It also have following advantages: simple structure, a few parts, no interspace loss, low noise



**Compact structure**

Units features compact structure, small installation area, advanced design. Its installation area is 70% of modular chiller with same capacity.

**Green**

Refrigerant	Molecular formula	ODP (ozone-depletion potential)	GWP (Global Warming Potential)	toxicity	flammability
R22	CHF2Cl	0.05	0.3	innocuous	nonflammable
R134a	C2H2F4	0	0.24-0.29	innocuous	nonflammable

**Optimized heat exchange system**

**Dry Type Evaporator**

Simple oil retrieval, high reliability without oil retrieval pump. Little cooling capacity loss. No wearable parts, Low maintenance cost. Less refrigerant charging volume, less influenced by the static pressure of refrigerant liquid. Thermal insulated with latest fire resistant and water proof material.

**Horizontal shell and tube type condenser**

High heat conducting coefficient. Less water consumption. Less heat conducting resistance. Lower vertical space requirement. Compact structure and easy operation management.

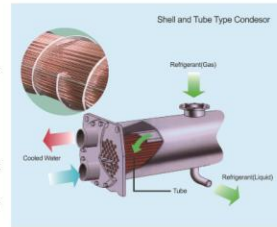

**High quality system component**

The key component of Chunlan chiller are supplied by well know corporations including Danfoss, Emerson and Sporlan. The performance are high reliable and the control are very accurate.



**Convenient Installation and Maintenance**

Lubricant oil and refrigerant has been charged in factory production. End user only need to connect the water pipe and electric wiring so as to put into use. This can greatly reduce the time for on spot installation and debugging.

**Humanized operation interface**



High-resolution LED backlight touch screen, 800\*480, 35535 digital true color display  
 Strong anti-interference performance, industrial standard III  
 Touch operation, menu with varied contents, easy to understand  
 Multistage menu  
 Multistage login permission settings, easy to manage  
 Real-time display of the operating data, Control the unit precisely in real-time,  
 timing for start-up and shut-down automatically

**Advanced intelligent centralized control system**

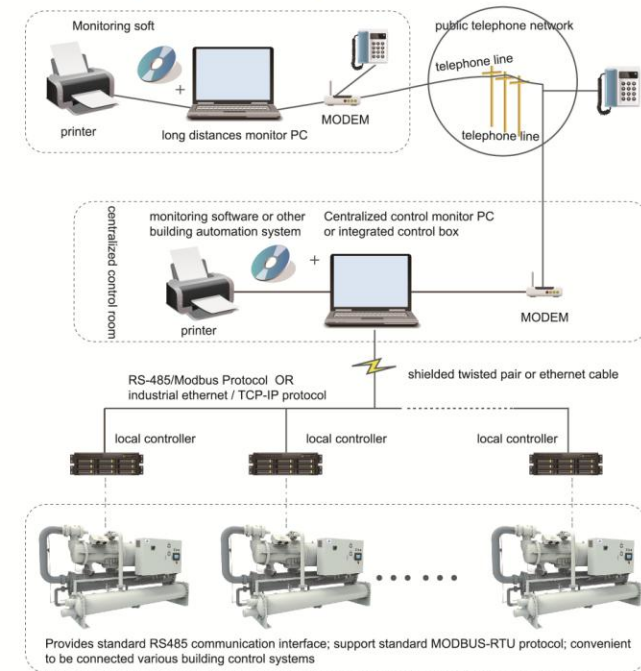

### Water system pipe connection

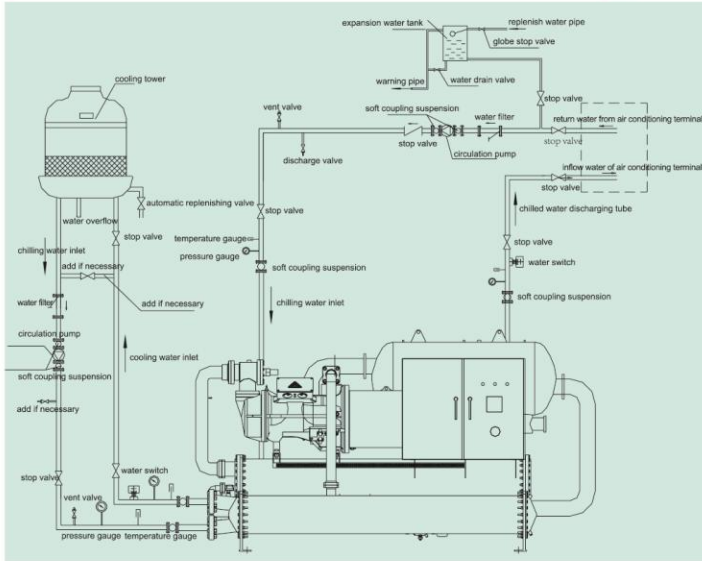

### R22 series scroll chiller

Model	CLS60WX2K	CLS80WX2K	CLS120WX3K
Cooling Capacity	kW 60	80	120
Power Input	kW 13.2	16.3	24.2
Operating Current	A 25.1	31.0	46.0

### R134a series scroll chiller

Model	CLS65WX2AK	CLS85WX2AK	CLS125WX3AK
Cooling Capacity	kW 65	84	123
Power Input	kW 13.9	17.2	24.8
Operating Current	A 26.4	32.7	47.1

### Cooling water filling system flow chart of Water chiller

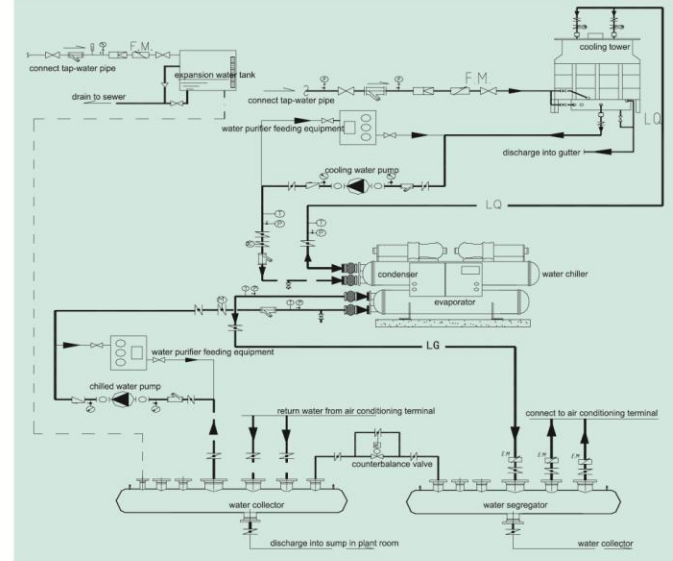

### R22 series water source heat pump scroll chiller

Model	CLS65RWX2KD	CLS85RWX2KD	CLS130RWX3KD
Cooling Capacity	kW 65	85	130
Heating Capacity	kW 71.5	93.5	143
Power Input	kW 12	13.6	20.5
Operating Current	A 22.8	25.8	39.0

### R134a series water source heat pump scroll chiller

Model	CLS65RWX2AKD	CLS85RWX2AKD	CLS125RWX3AKD
Cooling Capacity	kW 65	83	125
Heating Capacity	kW 71.5	91.3	137.5
Power Input	kW 10.9	16.8	24.4
Operating Current	A 20.7	31.9	46.4



Unit overall dimensions

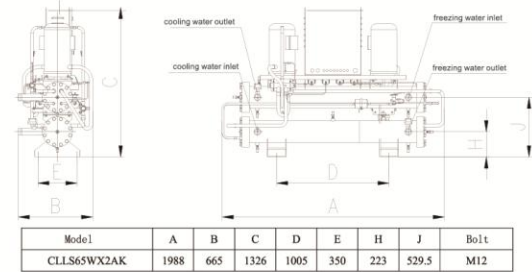

Model	A	B	C	D	E	H	J	Bolt
CLLS65WX2AK	1988	665	1326	1005	350	223	529.5	M12

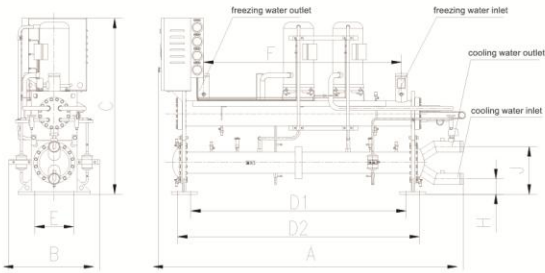

Model	A	B	C	D1	D2	E	F	H	J	Bolt
CLLS85WX2AK	2538	700	1368	1669	1873	300	1532	120	370	M16

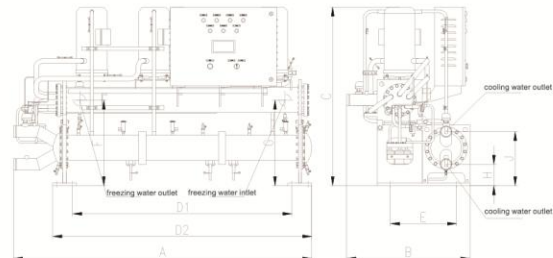

Model	A	B	C	D1	D2	E	F	G	H	J	Bolt
CLLS125WX3AK	2253	930	1363	1655	1955	500	653	653	163	413	M20

Specifications

Model		CLLS65WX2AK	CLLS85WX2AK	CLLS125WX3AK	
Cooling capacity	kW	65	84	123	
Heating capacity	kW	.....	.....	.....	
Power input	kW	13.9	17.2	24.8	
Rated current	A	26.4	32.7	47.1	
EER		4.68	4.88	4.96	
Capacity adjusting	%	50%-100%	50%-100%	33%-66%-100%	
Compressor	Type	hermetic scroll			
	Quantity	2	2	3	
	startup mode	Directly Starting	Directly Starting	Directly Starting	
Condenser	Type	closed shell and tube condenser			
	Quantity	2	2	3	
	Pipe diameter	DN	DN65	DN65	DN65
	Water flow	m <sup>3</sup> /h	13.5	17.3	25.3
	Water resistance	KPa	38	40	45
Evaporator	Type	Dry type evaporator	Dry type evaporator	Dry type evaporator	
	Quantity	1	1	1	
	Pipe diameter	DN	DN65	DN65	DN65
	Water flow	m <sup>3</sup> /h	11.1	14.4	21.1
Refrigerant	Water resistance	KPa	30	32	35
	Type	R410a			
	Charge	kg	15	18	27
Net weight	kg	530	580	750	
Running weight	kg	550	610	780	

1. The parameters in the above table is the nominal value in accordance with the rated conditions stipulated by the GB/T18430.1-2007.

Standard cooling condition: Evaporator water outlet temperature 7, Condenser water inlet temperature 30

Standard heating condition: Evaporator water inlet temperature 15, Condenser water outlet temperature 45

2. Energy efficiency rating is determined according to GB19577-2004

3. The particular parameters are subject to the nameplate of unit.

**R22 series dry type single screw chiller**

Model	CLLS300DL1K	CLLS430DL1K	CLLS500DL1K	CLLS550DL1K
Cooling Capacity	kW 300	430	500	550
Power Input	kW 64.5	92	106.5	116
Operating Current	A 116.1	165.6	191.7	208.8
Model	CLLS660DL1K	CLLS770DL1K	CLLS870DL1K	CLLS960DL1K
Cooling Capacity	kW 660	770	870	960
Power Input	kW 137	158	177	193
Operating Current	A 246.6	284.4	318.6	347.4
Model	CLLS860DL2K	CLLS1000DL2K	CLLS1090DL2K	CLLS1320DL2K
Cooling Capacity	kW 860	1000	1090	1320
Power Input	kW 173	198	214	256
Operating Current	A 311.4	356.4	385.2	460.8
Model	CLLS1550DL2K	CLLS1750DL2K	CLLS1900DL2K	CLLS2000DL2K
Cooling Capacity	kW 1550	1750	1900	2000
Power Input	kW 295	330	355	368
Operating Current	A 531.0	594.0	639.0	662.4

**R134a series dry type single screw chiller**

Model	CLLS300DL1AK	CLLS420DL1AK	CLLS560DL1AK	CLLS620DL1AK
Cooling Capacity	kW 300	420	560	620
Power Input	kW 65	90	118	129
Operating Current	A 117.0	162.0	212.4	232.2
Model	CLLS670DL1AK	CLLS760DL1AK	CLLS870DL1AK	CLLS960DL1AK
Cooling Capacity	kW 670	760	870	960
Power Input	kW 138	155	175	191
Operating Current	A 248.4	279.0	315.0	343.8
Model	CLLS850DL2AK	CLLS990DL2AK	CLLS1200DL2AK	CLLS1340DL2AK
Cooling Capacity	kW 850	990	1120	1340
Power Input	kW 173	198	218	257
Operating Current	A 311.4	356.4	392.4	462.6
Model	CLLS1520DL2AK	CLLS1740DL2AK	CLLS1910DL2AK	CLLS2000DL2AK
Cooling Capacity	kW 1520	1740	1910	2000
Power Input	kW 288	324	352	368
Operating Current	A 518.4	583.2	633.6	662.4

**R22 series fluided single screw chiller**

Model	CLLS320DL1KM	CLLS470DL1KM	CLLS540DL1KM	CLLS590DL1KM
Cooling Capacity	kW 320	470	540	590
Power Input	kW 66	95.3	106.5	115
Operating Current	A 118.8	171.5	191.7	207.0
Model	CLLS710DL1KM	CLLS840DL1KM	CLLS950DL1KM	CLLS1040DL1KM
Cooling Capacity	kW 710	840	950	1040
Power Input	kW 136	158	176	190
Operating Current	A 244.8	284.4	316.8	342.0
Model	CLLS770DL2KM	CLLS940DL2KM	CLLS1070DL2KM	CLLS1190DL2KM
Cooling Capacity	kW 770	940	1070	1190
Power Input	kW 148	177	196	212
Operating Current	A 266.4	318.6	352.8	381.6
Model	CLLS1430DL2KM	CLLS1670DL2KM	CLLS1900DL2KM	CLLS2000DL2KM
Cooling Capacity	kW 1430	1670	1900	2000
Power Input	kW 251	288	323	336
Operating Current	A 451.8	518.4	581.4	604.8

**R134a series fluided single screw chiller**

Model	CLLS320DL1AKM	CLLS380DL1AKM	CLLS460DL1AKM	CLLS540DL1AKM
Cooling Capacity	kW 320	380	460	540
Power Input	kW 65.5	77	92.3	105
Operating Current	A 117.9	138.6	166.1	189.0
Model	CLLS610DL1AKM	CLLS730DL1AKM	CLLS830DL1AKM	CLLS950DL1AKM
Cooling Capacity	kW 610	730	830	950
Power Input	kW 117	136	153	173
Operating Current	A 210.6	244.8	275.4	311.4
Model	CLLS760DL2AKM	CLLS930DL2AKM	CLLS1080DL2AKM	CLLS1220DL2AKM
Cooling Capacity	kW 760	930	1080	1220
Power Input	kW 146	175	198	216
Operating Current	A 262.8	315.0	356.4	388.8
Model	CLLS1340DL2AKM	CLLS1470DL2AKM	CLLS1690DL2AKM	CLLS2000DL2AKM
Cooling Capacity	kW 1340	1470	1690	2000
Power Input	kW 234	252	284	333
Operating Current	A 421.2	453.6	511.2	599.4

**R22 series dry type single screw water source heat pump chiller**

Model	CLLS320RDL1KD	CLLS380RDL1KD	CLLS460RDL1KD	CLLS530RDL1KD
Cooling Capacity	kW 320	380	460	530
Heating Capacity	kW 352	418	506	583
Power Input	kW 58	68	81.5	93
Operating Current	A 104.4	122.4	146.7	167.4
Model	CLLS580RDL1KD	CLLS700RDL1KD	CLLS820RDL1KD	CLLS930RDL1KD
Cooling Capacity	kW 580	700	820	930
Heating Capacity	kW 638	770	902	1023
Power Input	kW 101	120.5	139	155
Operating Current	A 181.8	216.9	250.2	279.0
Model	CLLS920RDL2KD	CLLS1060RDL2KD	CLLS1160RDL2KD	CLLS1400RDL2KD
Cooling Capacity	kW 920	1060	1160	1400
Heating Capacity	kW 1012	1166	1276	1540
Power Input	kW 159	181	196	234
Operating Current	A 286.2	325.8	352.8	421.2
Model	CLLS1640RDL2KD	CLLS1850RDL2KD	CLLS2050RDL2KD	CLLS2300RDL2KD
Cooling Capacity	kW 1640	1850	2050	2300
Heating Capacity	kW 1804	2035	2255	2530
Power Input	kW 271	303	328	363
Operating Current	A 487.8	545.4	590.4	653.4

**R22 series enclosed single screw chiller**

Model	CLLS350DL1F	CLLS430DL1F	CLLS500DL1F	CLLS770DL1F
Cooling Capacity	kW 350	430	500	770
Power Input	kW 75	90	101	152
Operating Current	A 135.0	162.0	181.8	273.6
Model	CLLS880DL1F	CLLS1540DL2F	CLLS1650DL2F	CLLS1750DL2F
Cooling Capacity	kW 880	1540	1650	1750
Power Input	kW 171	290	306	320
Operating Current	A 307.8	522.0	550.8	576.0

### R134a series dry type single screw water source heat pump chiller

Model	CLS300RDL1AKD	CLS380RDL1AKD	CLS450RDL1AKD	CLS530RDL1AKD
Cooling Capacity	kW 300	380	450	530
Heating Capacity	kW 330	418	495	583
Power Input	kW 54	67	78	91
Operating Current	A 97.2	120.6	140.4	163.8
Model	CLS660RDL1AKD	CLS720RDL1AKD	CLS810RDL1AKD	CLS930RDL1AKD
Cooling Capacity	kW 660	720	810	930
Heating Capacity	kW 726	792	891	1023
Power Input	kW 111.5	120	133	151
Operating Current	A 200.7	216.0	239.4	271.8
Model	CLS900RDL2AKD	CLS1050RDL2AKD	CLS1200RDL2AKD	CLS1440RDL2AKD
Cooling Capacity	kW 900	1050	1200	1440
Heating Capacity	kW 990	1155	1320	1584
Power Input	kW 146	169	191	227
Operating Current	A 262.8	304.2	343.8	408.6
Model	CLS1620RDL2AKD	CLS1860RDL2AKD	CLS2050RDL2AKD	CLS2300RDL2AKD
Cooling Capacity	kW 1620	1860	2050	2300
Heating Capacity	kW 1782	2046	2255	2530
Power Input	kW 288	324	352	368
Operating Current	A 518.4	583.2	633.6	662.4

### R22 series fluided single screw water source heat pump chiller

Model	CLS350RDL1KDM	CLS410RDL1KDM	CLS500RDL1KDM	CLS580RDL1KDM
Cooling Capacity	kW 350	410	500	580
Heating Capacity	kW 385	451	550	638
Power Input	kW 57	66	80	91.8
Operating Current	A 102.6	118.8	144.0	165.2
Model	CLS760RDL1KDM	CLS890RDL1KDM	CLS1000RDL1KDM	CLS1100RDL1KDM
Cooling Capacity	kW 760	890	1000	1100
Heating Capacity	kW 836	979	1100	1210
Power Input	kW 119	138	154	167.3
Operating Current	A 214.2	248.4	277.2	301.1
Model	CLS820RDL2KDM	CLS1000RDL2KDM	CLS1160RDL2KDM	CLS1250RDL2KDM
Cooling Capacity	kW 820	1000	1160	1250
Heating Capacity	kW 902	1100	1276	1375
Power Input	kW 128	154	177	189
Operating Current	A 230.4	277.2	318.6	340.2
Model	CLS1520RDL2KDM	CLS1800RDL2KDM	CLS2010RDL2KDM	CLS2300RDL2KDM
Cooling Capacity	kW 1520	1800	2010	2300
Heating Capacity	kW 1672	1980	2211	2530
Power Input	kW 228	268	296	336
Operating Current	A 410.4	482.4	532.8	604.8

### R134a series enclosed single screw chiller

Model	CLS350DL1AF	CLS420DL1AF	CLS500DL1AF	CLS760DL1AF
Cooling Capacity	kW 350	420	500	760
Power Input	kW 76	89	100.8	150
Operating Current	A 136.8	160.2	181.4	270.0
Model	CLS880DL1AF	CLS1520DL2AF	CLS1600DL2AF	CLS1750DL2AF
Cooling Capacity	kW 880	1520	1600	1750
Power Input	kW 172	292	303	328
Operating Current	A 309.6	525.6	545.4	590.4

### R134a series fluided single screw water source heat pump chiller

Model	CLS320RDL1AKDM	CLS370RDL1AKDM	CLS500RDL1AKDM	CLS580RDL1AKDM
Cooling Capacity	kW 320	370	500	580
Heating Capacity	kW 352	407	550	638
Power Input	kW 51.5	59	79	90.5
Operating Current	A 92.7	106.2	142.2	162.9
Model	CLS650RDL1AKDM	CLS780RDL1AKDM	CLS890RDL1AKDM	CLS1020RDL1AKDM
Cooling Capacity	kW 650	780	890	1020
Heating Capacity	kW 715	858	979	1122
Power Input	kW 100.4	119	135	153.5
Operating Current	A 180.7	214.2	243.0	276.3
Model	CLS820RDL2AKDM	CLS1160RDL2AKDM	CLS1300RDL2AKDM	CLS1420RDL2AKDM
Cooling Capacity	kW 820	1160	1300	1420
Heating Capacity	kW 902	1276	1430	1562
Power Input	kW 127	178	197	213
Operating Current	A 228.6	320.4	354.6	383.4
Model	CLS1560RDL2AKDM	CLS1780RDL2AKDM	CLS2040RDL2AKDM	CLS2300RDL2AKDM
Cooling Capacity	kW 1560	1780	2040	2300
Heating Capacity	kW 1716	1958	2244	2530
Power Input	kW 232	263	299	334
Operating Current	A 417.6	473.4	538.2	601.2

### R22 series enclosed single screw water source heat pump chiller

Model	CLS370RDL1FDF	CLS460RDL1FDF	CLS580RDL1FDF	CLS820RDL1FDF
Cooling Capacity	kW 370	460	580	820
Heating Capacity	kW 407	506	638	902
Power Input	kW 64	78	96	134
Operating Current	A 115.2	140.4	172.8	241.2
Model	CLS930RDL1FDF	CLS1530RDL2FDF	CLS1640RDL2FDF	CLS1780RDL2FDF
Cooling Capacity	kW 930	1530	1640	1780
Heating Capacity	kW 1023	1683	1804	1958
Power Input	kW 149.5	242	256	271
Operating Current	A 269.1	435.6	460.8	487.8

### R134a series enclosed single screw water source heat pump chiller

Model	CLS370RDL1AFD	CLS450RDL1AFD	CLS530RDL1AFD	CLS810RDL1AFD
Cooling Capacity	kW 370	450	530	810
Heating Capacity	kW 407	495	583	891
Power Input	kW 64.2	76	88	132
Operating Current	A 115.6	136.8	158.4	237.6
Model	CLS930RDL1AFD	CLS1550RDL2AFD	CLS1640RDL2AFD	CLS1780RDL2AFD
Cooling Capacity	kW 930	1550	1640	1780
Heating Capacity	kW 1023	1705	1804	1958
Power Input	kW 149	243	253	270
Operating Current	A 268.2	437.4	455.4	486.0

Unit overall dimensions

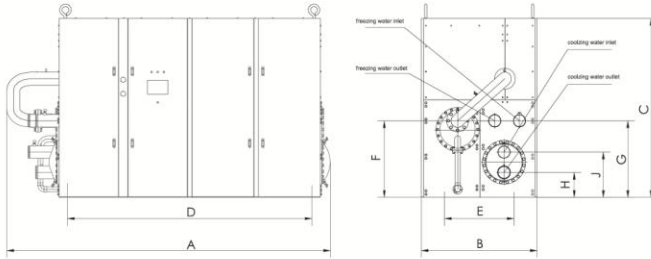

Model CLLS	A	B	C	D	E	F	G	H	J	cooling water/ freezing water connector
400RDL1AF	3370	1300	2035	2680	825	850	850	297	497	DN125
800RDL1AF	4184	1500	2290	3160	900	980	980	320	580	DN150

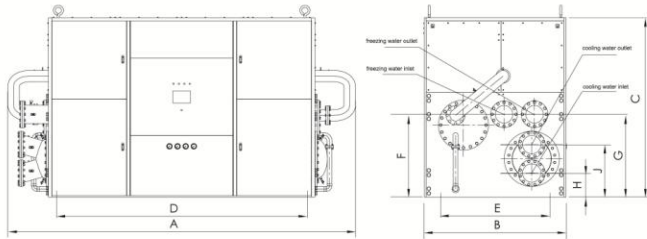

Model CLLS	A	B	C	D	E	F	G	H	J	cooling water/ freezing water connector
1600RDL2AF	5134	2095	2650	3700	1465	1222	1222	355	775	DN250

Specifications

Model		CLLS400RDL1AF	CLLS800RDL1AF	CLLS1600RDL2AF	
Cooling capacity	kW	400	800	1600	
Heating capacity	kW	425	950	1900	
Power input	kW	88	165	320	
Rated current	A	148	278	530	
EER		4.54	4.85	5.0	
Capacity adjusting	%	25%-100% stepless capacity adjusting			
Compressor	Type	semi-hermetic single screw			
	Quantity	1	1	2	
	startup mode	Y-Δ	Y-Δ	Y-Δ	
Condenser	Type	closed shell and tube condenser			
	Quantity	1	1	1	
	Pipe diameter	DN	DN125	DN150	DN250
	Water flow	m <sup>3</sup> /h	83.6	164	328
Water resistance	KPa	58	78	110	
Evaporator	Type	Dry type evaporator	Dry type evaporator	Dry type evaporator	
	Quantity	1	1	1	
	Pipe diameter	DN	DN125	DN150	DN250
	Water flow	m <sup>3</sup> /h	68.3	138	276
Water resistance	KPa	73	85	88	
Refrigerant	Type	R134a	R134a	R134a	
	Charge	kg	95	205	205x2
	Net weight	kg	3100	6000	10800
Running weight	kg	3250	6240	11280	

1. The parameters in the above table is the nominal value in accordance with the rated conditions stipulated by the GB/T18430.1-2007.

Standard cooling condition: Evaporator water outlet temperature 7, Condenser water inlet temperature 30

Standard heating condition: Evaporator water inlet temperature 15, Condenser water outlet temperature 45

2. Energy efficiency rating is determined according to GB19577-2004

3. The particular parameters are subject to the nameplate of unit.

R22 series twin screw water-cooled chiller

Model	CLLS150SL1K	CLLS180SL1K	CLLS210SL1K	CLLS250SL1K
Cooling Capacity	kW 150	180	210	250
Power Input	kW 33	39.4	45.8	54.1
Operating Current	A 58.1	69.3	80.6	95.2
Model	CLLS300SL1K	CLLS350SL1K	CLLS400SL1K	CLLS510SL1K
Cooling Capacity	kW 300	350	400	510
Power Input	kW 64.8	75.5	86	109
Operating Current	A 114.0	132.9	151.4	196.2
Model	CLLS560SL1K	CLLS610SL1K	CLLS660SL1K	CLLS710SL1K
Cooling Capacity	kW 560	610	660	710
Power Input	kW 119	128.5	138	148
Operating Current	A 214.2	231.3	248.4	266.4
Model	CLLS770SL1K	CLLS880SL1K	CLLS1010SL2K	CLLS1200SL2K
Cooling Capacity	kW 770	880	810	880
Power Input	kW 159	178	164	176
Operating Current	A 286.2	320.4	298	320
Model	CLLS980SL2K	CLLS1080SL2K	CLLS1150SL2K	CLLS1260SL2K
Cooling Capacity	kW 980	1080	1150	1260
Power Input	kW 195	213.5	226	246
Operating Current	A 355	389	411	448
Model	CLLS1350SL2K	CLLS1420SL2K	CLLS1540SL2K	CLLS1620SL2K
Cooling Capacity	kW 1350	1420	1540	1620
Power Input	kW 262	273.8	295	308
Operating Current	A 477	493	531	554
Model	CLLS1700SL2K	CLLS1760SL2K	CLLS1840SL2K	CLLS2000SL2K
Cooling Capacity	kW 1700	1760	1840	2000
Power Input	kW 322	332	345	367
Operating Current	A 580	598	621	661

R134a series twin screw water-cooled chiller

Model	CLLS150SL1AK	CLLS180SL1AK	CLLS210SL1AK	CLLS280SL1AK
Cooling Capacity	kW 150	180	210	280
Power Input	kW 33	39.4	46	60.8
Operating Current	A 58.7	70.1	81.9	108.2
Model	CLLS320SL1AK	CLLS370SL1AK	CLLS460SL1AK	CLLS520SL1AK
Cooling Capacity	kW 320	370	460	520
Power Input	kW 69.3	80	99	111
Operating Current	A 123.4	142.4	176.2	199.8
Model	CLLS610SL1AK	CLLS660SL1AK	CLLS700SL1AK	CLLS750SL1AK
Cooling Capacity	kW 610	660	700	750
Power Input	kW 126	138	145	155
Operating Current	A 226.8	248.4	261	279
Model	CLLS810SL1AK	CLLS880SL1AK	CLLS800SL2AK	CLLS850SL2AK
Cooling Capacity	kW 810	880	800	850
Power Input	kW 166	179	164	174
Operating Current	A 298.8	322.2	298.5	316.7
Model	CLLS990SL2AK	CLLS980SL2AK	CLLS1100SL2AK	CLLS1120SL2AK
Cooling Capacity	kW 900	980	1100	1120
Power Input	kW 183	198	218	221
Operating Current	A 333.1	356.4	392.4	397.8
Model	CLLS1200SL2AK	CLLS1340SL2AK	CLLS1400SL2AK	CLLS1510SL2AK
Cooling Capacity	kW 1200	1340	1400	1510
Power Input	kW 235	260	270	288
Operating Current	A 427.7	473.2	491.4	524.2
Model	CLLS1630SL2AK	CLLS1760SL2AK	CLLS1870SL2AK	CLLS2000SL2AK
Cooling Capacity	kW 1630	1760	1870	2000
Power Input	kW 308	325	342	362
Operating Current	A 569.8	601.3	632.7	669.7

R22 series fluided twin screw chiller

Model	CLLS210SL1KM	CLLS300SL1KM	CLLS370SL1KM	CLLS440SL1KM
Cooling Capacity	kW 210	300	370	440
Power Input	kW 44	62	75	88.5
Operating Current	A 79.2	111.6	135.0	159.3
Model	CLLS440SL1KM	CLLS610SL1KM	CLLS710SL1KM	CLLS780SL1KM
Cooling Capacity	kW 540	610	710	780
Power Input	kW 105.6	118	136	148
Operating Current	A 190.1	212.4	244.8	266.4
Model	CLLS870SL1KM	CLLS960SL1KM	CLLS1050SL1KM	CLLS1130SL1KM
Cooling Capacity	kW 870	960	1050	1130
Power Input	kW 164	178	193	206
Operating Current	A 295.2	320.4	347.4	370.8
Model	CLLS760SL2KM	CLLS880SL2KM	CLLS940SL2KM	CLLS1090SL2KM
Cooling Capacity	kW 760	880	940	1090
Power Input	kW 143	164	173	199
Operating Current	A 257.4	295.2	311.4	358.2
Model	CLLS1160SL2KM	CLLS1280SL2KM	CLLS1400SL2KM	CLLS1520SL2KM
Cooling Capacity	kW 1160	1280	1400	1520
Power Input	kW 210	226	245	263.5
Operating Current	A 378.0	406.8	441.0	474.3
Model	CLLS1660SL2KM	CLLS1780SL2KM	CLLS1870SL2KM	CLLS2000SL2KM
Cooling Capacity	kW 1660	1780	1870	2000
Power Input	kW 286	306	319	339
Operating Current	A 514.8	550.8	574.2	610.2

R134a series fluided twin screw chiller

Model	CLLS210SL1AKM	CLLS280SL1AKM	CLLS360SL1AKM	CLLS480SL1AKM
Cooling Capacity	kW 210	280	360	480
Power Input	kW 43.8	58	73.4	96.2
Operating Current	A 78.8	104.4	132.1	173.2
Model	CLLS440SL1AKM	CLLS630SL1AKM	CLLS680SL1AKM	CLLS760SL1AKM
Cooling Capacity	kW 540	630	680	760
Power Input	kW 105.6	121	129	142
Operating Current	A 190.1	217.8	232.2	255.6
Model	CLLS850SL1AKM	CLLS980SL1KM	CLLS1060SL1KM	CLLS1150SL1KM
Cooling Capacity	kW 850	980	1060	1150
Power Input	kW 158	180	193.2	205.8
Operating Current	A 284.4	324.0	347.8	370.4
Model	CLLS740SL2AKM	CLLS830SL2AKM	CLLS950SL2AKM	CLLS1030SL2AKM
Cooling Capacity	kW 740	830	950	1030
Power Input	kW 143	160	181	193
Operating Current	A 257.4	288	325.8	347.4
Model	CLLS1120SL2AKM	CLLS1200SL2AKM	CLLS1300SL2AKM	CLLS1390SL2AKM
Cooling Capacity	kW 1120	1200	1300	1390
Power Input	kW 208	220	237	251
Operating Current	A 374.4	396	426.6	451.8
Model	CLLS1520SL2AKM	CLLS1650SL2AKM	CLLS1860SL2AKM	CLLS2000SL2AKM
Cooling Capacity	kW 1520	1650	1860	2000
Power Input	kW 273	294	329	352
Operating Current	A 491.4	529.2	592.2	633.6

R22 series twin screw water source heat pump chiller

Model	CLLS180RSLIKD	CLLS210RSLIKD	CLLS260RSLIKD	CLLS330RSLIKD
Cooling Capacity	kW 180	210	260	330
Heating Capacity	kW 198	231	286	363
Power Input	kW 34	39.4	48.6	61.5
Operating Current	A 59.8	69.3	85.5	108.2
Model	CLLS430RSLIKD	CLLS500RSLIKD	CLLS550RSLIKD	CLLS600RSLIKD
Cooling Capacity	kW 430	500	550	600
Heating Capacity	kW 473	550	605	660
Power Input	kW 79.2	91	99	107
Operating Current	A 139.4	160.2	178.2	192.6
Model	CLLS710RSLIKD	CLLS760RSLIKD	CLLS810RSLIKD	CLLS870RSLIKD
Cooling Capacity	kW 710	760	810	870
Heating Capacity	kW 781	836	891	957
Power Input	kW 125.2	133	141	150
Operating Current	A 225.36	239.4	253.8	270
Model	CLLS950RSLIKD	CLLS880RSL2KD	CLLS950RSL2KD	CLLS1060RSL2KD
Cooling Capacity	kW 950	880	950	1060
Heating Capacity	kW 1045	968	1045	1166
Power Input	kW 162	155	166	184
Operating Current	A 291.6	282	302	335
Model	CLLS1130RSL2KD	CLLS1230RSL2KD	CLLS1340RSL2KD	CLLS1500RSL2KD
Cooling Capacity	kW 1130	1230	1340	1500
Heating Capacity	kW 1243	1353	1474	1650
Power Input	kW 195	211	229.5	255
Operating Current	A 355	384	418	459
Model	CLLS1960RSL2KD	CLLS2050RSL2KD	CLLS2130RSL2KD	CLLS2300RSL2KD
Cooling Capacity	kW 1960	2050	2130	2300
Heating Capacity	kW 2156	2255	2343	2530
Power Input	kW 328	337	348	373
Operating Current	A 590	607	626	671

R134a series twin screw water source heat pump chiller

Model	CLLS180RSLIAKD	CLLS220RSLIAKD	CLLS270RSLIAKD	CLLS340RSLIAKD
Cooling Capacity	kW 180	220	270	340
Heating Capacity	kW 198	242	297	374
Power Input	kW 33	39.8	48	60
Operating Current	A 58.1	70.0	84.5	105.6
Model	CLLS370RSLIAKD	CLLS430RSLIAKD	CLLS530RSLIAKD	CLLS600RSLIAKD
Cooling Capacity	kW 370	430	530	600
Heating Capacity	kW 407	473	583	638
Power Input	kW 64.5	74	90.2	98
Operating Current	A 113.5	130.2	158.8	176.4
Model	CLLS620RSLIAKD	CLLS690RSLIAKD	CLLS760RSLIAKD	CLLS850RSLIAKD
Cooling Capacity	kW 620	690	760	850
Heating Capacity	kW 682	759	836	935
Power Input	kW 103.6	114	124.3	138
Operating Current	A 186.48	205.2	223.74	248.4
Model	CLLS870RSL2AKD	CLLS920RSL2AKD	CLLS1060RSL2AKD	CLLS1170RSL2AKD
Cooling Capacity	kW 870	920	1060	1170
Heating Capacity	kW 957	1012	1166	1287
Power Input	kW 142	149	171	187
Operating Current	A 258	271	311	340
Model	CLLS1230RSL2AKD	CLLS1360RSL2AKD	CLLS1430RSL2AKD	CLLS1540RSL2AKD
Cooling Capacity	kW 1230	1360	1430	1540
Heating Capacity	kW 1353	1496	1573	1694
Power Input	kW 195	215	225	241
Operating Current	A 355	391	405	434
Model	CLLS1700RSL2AKD	CLLS1850RSL2AKD	CLLS2000RSL2AKD	CLLS2300RSL2AKD
Cooling Capacity	kW 1700	1850	2000	2300
Heating Capacity	kW 1870	2035	2200	2530
Power Input	kW 264	285	305	349
Operating Current	A 475	513	549	628

R22 series fluided twin screw water source heat pump chiller

Model	CLLS210RSLIKDM	CLLS310RSLIKDM	CLLS380RSLIKDM	CLLS450RSLIKDM
Cooling Capacity	kW 210	310	380	450
Heating Capacity	kW 231	341	418	495
Power Input	kW 34.2	50	61	71.8
Operating Current	A 61.6	90.0	109.8	129.2
Model	CLLS500RSLIKDM	CLLS590RSLIKDM	CLLS690RSLIKDM	CLLS770RSLIKDM
Cooling Capacity	kW 500	590	690	770
Heating Capacity	kW 550	649	759	847
Power Input	kW 79	92.5	107.6	119.5
Operating Current	A 142.2	166.5	193.7	215.1
Model	CLLS900RSLIKDM	CLLS990RSLIKDM	CLLS1060RSLIKDM	CLLS1190RSLIKDM
Cooling Capacity	kW 900	990	1050	1190
Heating Capacity	kW 990	1089	1166	1309
Power Input	kW 139	151	161	179
Operating Current	A 250.2	271.8	289.8	322.2
Model	CLLS760RSL2KDM	CLLS840RSL2KDM	CLLS910RSL2KDM	CLLS1000RSL2KDM
Cooling Capacity	kW 760	840	910	1000
Heating Capacity	kW 836	924	1001	1100
Power Input	kW 118	130	140	153
Operating Current	A 212.4	234.0	252.0	275.4
Model	CLLS1200RSL2KDM	CLLS1260RSL2KDM	CLLS1370RSL2KDM	CLLS1480RSL2KDM
Cooling Capacity	kW 1200	1260	1370	1480
Heating Capacity	kW 1320	1386	1507	1628
Power Input	kW 182	190	206	221.5
Operating Current	A 327.6	342.0	370.8	398.7
Model	CLLS1550RSL2KDM	CLLS1670RSL2KDM	CLLS1800RSL2KDM	CLLS2000RSL2KDM
Cooling Capacity	kW 1550	1670	1800	2000
Heating Capacity	kW 1705	1837	1980	2200
Power Input	kW 230	306	319	339
Operating Current	A 414.0	550.8	574.2	610.2

R134a series fluided twin screw water source heat pump chiller

Model	CLLS210RSLIAKDM	CLLS280RSLIAKDM	CLLS380RSLIAKDM	CLLS450RSLIAKDM
Cooling Capacity	kW 210	280	380	450
Heating Capacity	kW 231	308	418	495
Power Input	kW 34	45	60.5	71
Operating Current	A 61.2	81.0	108.9	127.8
Model	CLLS520RSLIAKDM	CLLS600RSLIAKDM	CLLS660RSLIAKDM	CLLS700RSLIAKDM
Cooling Capacity	kW 520	600	660	700
Heating Capacity	kW 572	660	726	770
Power Input	kW 81.5	93.4	102.4	108
Operating Current	A 146.7	168.1	184.3	194.4
Model	CLLS770RSLIAKDM	CLLS960RSLIAKDM	CLLS1120RSLIAKDM	CLLS1280RSLIAKDM
Cooling Capacity	kW 770	960	1120	1280
Heating Capacity	kW 847	1056	1232	1408
Power Input	kW 118	146	169	192
Operating Current	A 212.4	262.8	304.2	345.6
Model	CLLS760RSL2AKDM	CLLS830RSL2AKDM	CLLS910RSL2AKDM	CLLS1000RSL2AKDM
Cooling Capacity	kW 760	830	910	1000
Heating Capacity	kW 836	913	1001	1100
Power Input	kW 118	128	139	152
Operating Current	A 212.4	230.4	250.2	273.6
Model	CLLS1110RSL2AKDM	CLLS1200RSL2AKDM	CLLS1320RSL2AKDM	CLLS1380RSL2AKDM
Cooling Capacity	kW 1110	1200	1320	1380
Heating Capacity	kW 1221	1320	1452	1518
Power Input	kW 168	181	198	206
Operating Current	A 302.4	325.8	356.4	370.8
Model	CLLS1540RSL2AKDM	CLLS1710RSL2AKDM	CLLS1880RSL2AKDM	CLLS2000RSL2AKDM
Cooling Capacity	kW 1540	1710	1880	2000
Heating Capacity	kW 1694	1881	2068	2200
Power Input	kW 228	251	275	290
Operating Current	A 410.4	451.8	495	522

R22 series falling film screw chiller

<b>Model</b>	CLS210SL1KJ	CLS300SL1KJ	CLS370SL1KJ	CLS440SL1KJ
Cooling Capacity kW	210	300	370	440
Power Input kW	44	62	75	88.5
Operating Current A	79.2	111.6	135.0	159.3
<b>Model</b>	CLS440SL1KJ	CLS610SL1KJ	CLS710SL1KJ	CLS780SL1KJ
Cooling Capacity kW	540	610	710	780
Power Input kW	105.6	118	136	148
Operating Current A	190.1	212.4	244.8	266.4
<b>Model</b>	CLS870SL1KJ	CLS960SL1KJ	CLS1050SL1KJ	CLS1130SL1KJ
Cooling Capacity kW	870	960	1050	1130
Power Input kW	164	178	193	206
Operating Current A	295.2	320.4	347.4	370.8
<b>Model</b>	CLS760SL2KJ	CLS880SL2KJ	CLS940SL2KJ	CLS1090SL2KJ
Cooling Capacity kW	760	880	940	1090
Power Input kW	143	164	173	199
Operating Current A	257.4	295.2	311.4	358.2

<b>Model</b>	CLS1160SL2KJ	CLS1280SL2KJ	CLS1400SL2KJ	CLS1520SL2KJ
Cooling Capacity kW	1160	1280	1400	1520
Power Input kW	210	226	245	263.5
Operating Current A	378.0	406.8	441.0	474.3
<b>Model</b>	CLS16600SL2KJ	CLS1780SL2KJ	CLS1870SL2KJ	CLS2000SL2KJ
Cooling Capacity kW	1660	1780	1870	2000
Power Input kW	286	306	319	339
Operating Current A	514.8	550.8	574.2	610.2

R134A series falling film screw chiller

<b>Model</b>	CLS210SL1AKJ	CLS280SL1AKJ	CLS360SL1AKJ	CLS480SL1AKJ
Cooling Capacity kW	210	280	360	480
Power Input kW	43.8	58	73.4	96.2
Operating Current A	78.8	104.4	132.1	173.2
<b>Model</b>	CLS460SL1AKJ	CLS630SL1AKJ	CLS680SL1AKJ	CLS760SL1AKJ
Cooling Capacity kW	540	630	680	760
Power Input kW	105.6	121	129	142
Operating Current A	190.1	217.8	232.2	255.6
<b>Model</b>	CLS850SL1AKJ	CLS980SL1AKJ	CLS1060SL1AKJ	CLS1150SL1AKJ
Cooling Capacity kW	850	980	1060	1150
Power Input kW	158	180	193.2	205.8
Operating Current A	284.4	324.0	347.8	370.4
<b>Model</b>	CLS740SL2AKJ	CLS830SL2AKJ	CLS950SL2AKJ	CLS1030SL2AKJ
Cooling Capacity kW	740	830	950	1030
Power Input kW	143	160	181	193
Operating Current A	257.4	288	325.8	347.4
<b>Model</b>	CLS1120SL2AKJ	CLS1200SL2AKJ	CLS1300SL2AKJ	CLS1390SL2AKJ
Cooling Capacity kW	1120	1200	1300	1390
Power Input kW	208	220	237	251
Operating Current A	374.4	396	426.6	451.8
<b>Model</b>	CLS1520SL2AKJ	CLS1650SL2AKJ	CLS1860SL2AKJ	CLS2000SL2AKJ
Cooling Capacity kW	1520	1650	1860	2000
Power Input kW	273	294	329	352
Operating Current A	491.4	529.2	592.2	633.6

R22 series falling film water source heat pump chiller

<b>Model</b>	CLS210RSL1KDJ	CLS310RSL1KDJ	CLS380RSL1KDJ	CLS450RSL1KDJ
Cooling Capacity kW	210	310	380	450
Heating Capacity kW	231	341	418	495
Power Input kW	34.2	50	61	71.8
Operating Current A	61.6	90.0	109.8	129.2
<b>Model</b>	CLS500RSL1KDJ	CLS590RSL1KDJ	CLS690RSL1KDJ	CLS770RSL1KDJ
Cooling Capacity kW	500	590	690	770
Heating Capacity kW	550	649	759	847
Power Input kW	79	92.5	107.6	119.5
Operating Current A	142.2	166.5	193.7	215.1
<b>Model</b>	CLS900RSL1KDJ	CLS990RSL1KDJ	CLS1060RSL1KDJ	CLS1190RSL1KDJ
Cooling Capacity kW	900	990	1060	1190
Heating Capacity kW	990	1089	1166	1309
Power Input kW	139	151	161	179
Operating Current A	250.2	271.8	289.8	322.2

<b>Model</b>	CLS760RSL2KDJ	CLS840RSL2KDJ	CLS910RSL2KDJ	CLS1000RSL2KDJ
Cooling Capacity kW	760	840	910	1000
Heating Capacity kW	836	924	1001	1100
Power Input kW	118	130	140	153
Operating Current A	212.4	234.0	252.0	275.4
<b>Model</b>	CLS1200RSL2KDJ	CLS1260RSL2KDJ	CLS1370RSL2KDJ	CLS1480RSL2KDJ
Cooling Capacity kW	1200	1260	1370	1480
Heating Capacity kW	1320	1386	1507	1628
Power Input kW	182	190	206	221.5
Operating Current A	327.6	342.0	370.8	398.7
<b>Model</b>	CLS1550RSL2KDJ	CLS1670RSL2KDJ	CLS1800RSL2KDJ	CLS2000RSL2KDJ
Cooling Capacity kW	1550	1600	1800	2000
Heating Capacity kW	1705	1837	1980	2200
Power Input kW	231	247.5	264	290
Operating Current A	415.8	445.5	475.2	522.0

R134A series falling film water source heat pump chiller

<b>Model</b>	CLS210RSL1AKDJ	CLS280RSL1AKDJ	CLS380RSL1AKDJ	CLS450RSL1AKDJ
Cooling Capacity kW	210	280	380	450
Heating Capacity kW	231	308	418	495
Power Input kW	34	45	60.5	71
Operating Current A	61.2	81.0	108.9	127.8
<b>Model</b>	CLS520RSL1AKDJ	CLS600RSL1AKDJ	CLS660RSL1AKDJ	CLS700RSL1AKDJ
Cooling Capacity kW	520	600	660	700
Heating Capacity kW	572	660	726	770
Power Input kW	81.5	93.4	102.4	108
Operating Current A	146.7	168.1	184.3	194.4
<b>Model</b>	CLS770RSL1AKDJ	CLS960RSL1AKDJ	CLS1120RSL1AKDJ	CLS1280RSL1AKDJ
Cooling Capacity kW	770	960	1120	1280
Heating Capacity kW	847	1056	1232	1408
Power Input kW	118	128	146	152
Operating Current A	212.4	262.8	304.2	345.6
<b>Model</b>	CLS760RSL2AKDJ	CLS830RSL2AKDJ	CLS910RSL2AKDJ	CLS1000RSL2AKDJ
Cooling Capacity kW	760	830	910	1000
Heating Capacity kW	836	913	1001	1100
Power Input kW	118	128	139	152
Operating Current A	212.4	230.4	250.2	273.6
<b>Model</b>	CLS1110RSL2AKDJ	CLS1200RSL2AKDJ	CLS1320RSL2AKDJ	CLS1380RSL2AKDJ
Cooling Capacity kW	1110	1200	1320	1380
Heating Capacity kW	1221	1320	1452	1518
Power Input kW	168	181	198	206
Operating Current A	302.4	325.8	356.4	370.8
<b>Model</b>	CLS1540RSL2AKDJ	CLS1710RSL2AKDJ	CLS1880RSL2AKDJ	CLS2000RSL2AKDJ
Cooling Capacity kW	1540	1710	1880	2000
Heating Capacity kW	1694	1881	2068	2200
Power Input kW	228	251	275	290
Operating Current A	410.4	451.8	495	522

Unit overall dimensions

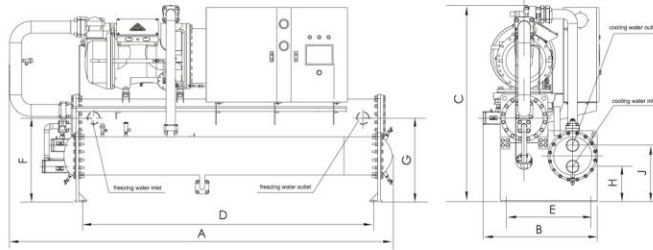

Model CLLS	A	B	C	D	E	F	G	H	J	cooling water/ freezing water connector
210SL1AK	3257	986	1645	2470	725	710	710	300	480	DN100
400SL1AK	3754	1060	1905	2680	825	725	725	262	462	DN125

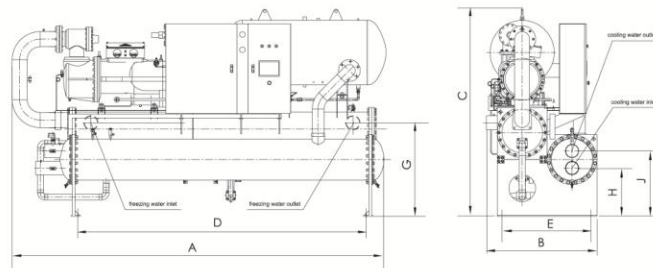

Model CLLS	A	B	C	D	E	F	G	H	J	cooling water/ freezing water connector
790SL1AK	4234	1440	2210	3240	1240	942	942	402	662	DN150

Specifications

Model		CLLS210RSL1AK	CLLS400RSL1AK	CLLS790RSL1AK	
Cooling capacity	kW	210	400	790	
Heating capacity	kW	226	428	930	
Power input	kW	49.1	88	165	
Rated current	A	94	148	278	
EER		4.28	4.54	4.79	
Capacity adjusting	%	25%、50%、75%、100%			
Compressor	Type	semi-hermetic twin screw			
	Quantity	1	1	1	
	startup mode	Y-Δ	Y-Δ	Y-Δ	
Condenser	Type	closed shell and tube condenser			
	Quantity	1	1	1	
	Pipe diameter	DN	DN100	DN125	DN150
	Water flow	m <sup>3</sup> /h	44.5	83.6	164
Water resistance	KPa	53	58	82	
Evaporator	Type	Dry type evaporator	Dry type evaporator	Dry type evaporator	
	Quantity	1	1	1	
	Pipe diameter	DN	DN100	DN125	DN150
	Water flow	m <sup>3</sup> /h	36	68.3	136
Water resistance	KPa	45	73	80	
Refrigerant	Type	R134a	R134a	R134a	
	Charge	kg	50	95	200
Net weight	kg	1450	2700	4800	
Running weight	kg	1600	2900	5050	

1. The parameters in the above table is the nominal value in accordance with the rated conditions stipulated by the GB/T18430.1-2007.

Standard cooling condition: Evaporator water outlet temperature 7, Condenser water inlet temperature 30

Standard heating condition: Evaporator water inlet temperature 15, Condenser water outlet temperature 45

2. Energy efficiency rating is determined according to GB19577-2004

3. The particular parameters are subject to the nameplate of unit.



Horizontal concealed FP-WA

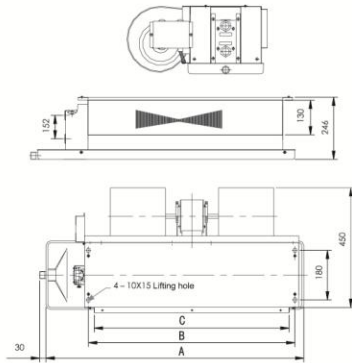

Model	A	B	C	Weight kg
FP-34	840	520	480	13
FP-51	940	620	580	16.5
FP-68	1040	720	680	18
FP-85	1140	820	780	19
FP-102	1240	920	880	20.5
FP-136	1540	1220	1180	24
FP-170	1740	1420	1380	26
FP-204	1840	1560	1520	28
FP-238	2040	1760	1720	29.5

Horizontal open-mounted FP-WM

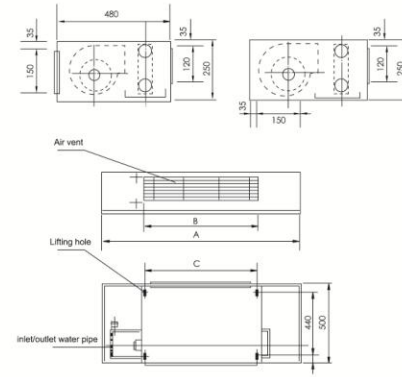

Model	A	B	C
FP-34	900	480	520
FP-51	1100	580	620
FP-68	1100	680	720
FP-85	1200	780	820
FP-102	1300	880	920
FP-136	1600	1180	1220
FP-170	1800	1380	1420
FP-204	1940	1520	1560
FP-238	2140	1720	1760

Horizontal concealed(with air return box) FP-WAX(H)

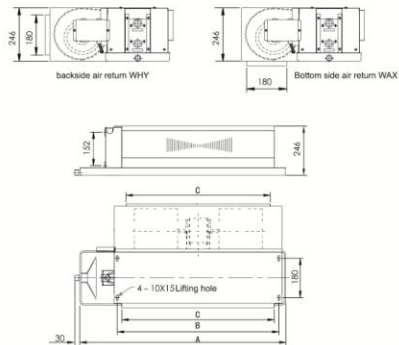

Model	A	B	C	Weight kg
FP-34	840	520	480	15
FP-51	940	620	580	18
FP-68	1040	720	680	21.5
FP-85	1140	820	780	22.5
FP-102	1240	920	880	24.5
FP-136	1540	1220	1180	30
FP-170	1740	1420	1380	32.5
FP-204	1840	1560	1520	34.5
FP-238	2040	1760	1720	37.5

Vertical concealed FP-LA

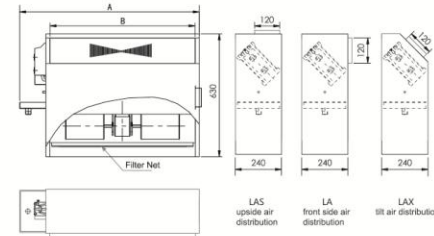

Model	FP-34	FP-51	FP-68	FP-85	FP-102	FP-136	FP-170	FP-204	FP-238
A	650	750	850	950	1050	1350	1550	1690	1890
B	480	580	680	780	880	1180	1380	1520	1720

Vertical open mounted

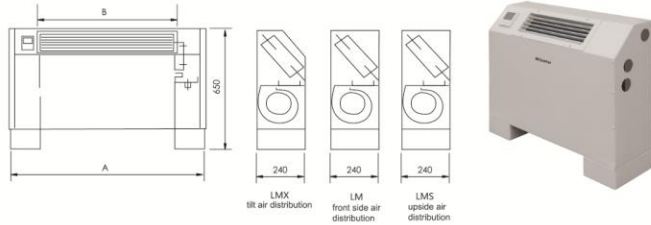

	FP-34	FP-51	FP-68	FP-85	FP-102	FP-136	FP-170	FP-204	FP-238
A	800	900	1000	1100	1200	1500	1700	1850	2050
B	480	580	680	780	880	1180	1380	1520	1720
Weight kg	18.5	22.5	24	28	30	45	50	55	55

Optional accessory

Mechanical controller



Capacitor type touch screen electronic controller



LCD electronic controller



Mechanical controller

Air vent, Service Point



Performance

Model	Imperial system model	FC200	FC300	FC400	FC500	FC800	FC1000	FC1200	FC1400		
	Metric system model	FP-34	FP-51	FP-68	FP-85	FP-102	FP-136	FP-170	FP-204	FP-238	
Air flow m <sup>3</sup> /h	H	340	510	680	850	1020	1360	1700	2040	2385	
	M	255	383	510	638	765	1020	1275	1530	1785	
	L	170	255	340	425	510	680	850	1020	1190	
Cooling Capacity W	H	1800	2700	3600	4500	5400	7200	9000	10800	12600	
	M	1620	2440	3290	4120	4950	6550	8190	9730	11580	
	L	1310	2010	2650	3320	3900	5300	6610	7860	9350	
Heating Capacity W	H	2700	4050	5400	6750	8100	10800	13500	16200	18900	
	M	2350	3520	4530	5640	6850	9260	11740	14140	16365	
	L	1620	2470	3130	4170	4740	6500	8180	9710	11290	
Noise dB (A)	low static pressure 12Pa	≤35	≤36	≤37	≤41	≤43	≤44	≤46	≤47	≤48	
	high static pressure 20Pa	≤37	≤38	≤41	≤44	≤45	≤46	≤48	≤49	≤50	
	high static pressure 50Pa	≤40	≤41	≤44	≤45	≤46	≤48	≤49	≤50	≤52	
Cold water return water temperature							7°C - 12°C				
Hot water supply water temperature							40°C - 60°C				
Power Supply	AC220V/50Hz										
Heat exchanger	Type	seamless copper tube, aluminum fin									
	Pressure	1.6MPa									
	3-row water supply quantity water resistance	324	482	655	814	936	1278	1602	1915	2178	
low static pressure unit 12Pa	W	37	52	62	76	96	134	152	189	228	
	high static pressure unit 30Pa	W	44	59	72	87	108	156	174	212	253
fan coil unit quantity	50Pa	W	49	66	84	100	118	174	210	250	300
	inlet water pipe	1	2	2	2	3	3	4	4	4	
Pipe size	inlet water pipe	3/4" inner grooved									
	outlet water pipe	3/4" external grooved									

Air Handling Unit

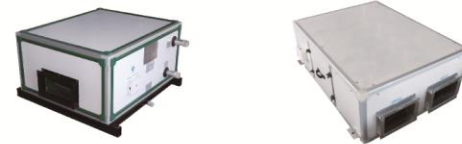

Air Valve





Enclosure Air Conditioners

**Intelligent Temperature Control**

Automatic control the temperature inside the cabinet and the station. The control system will detect the temperature of the return air through inner circulation temperature sensor, to compare and diagnose with the settings, to control the running.

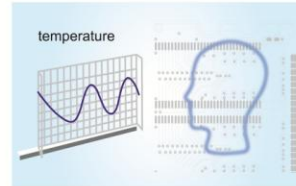

**Automatic discharge the hydrogen**

Automatic discharge hydrogen with environmental requirements of device cabinet. When setting the timer of automatic discharging hydrogen, the unit will open the discharging hydrogen fan automatic and timely. Besides, it also can be manualled operation, through man-machine interaction interface operation, to discharge the hydrogen.

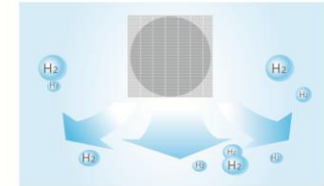

**Linkage control**

linked with the external air conditioner systems, and coordinated operation with them. It has two modes, one is power control mode, another is simulation button control mode.

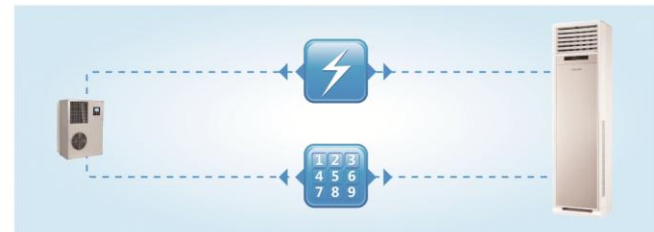

**Intelligent Self-checking Function**

Automatic judgment abnormal condition  
 Convenient timely and accurate maintenance  
 Exempt from worries for the future  
 The function to test the fan can regulate fan speed and test fan operation according to the set temperature.  
 If there are several groups of fans, anyone of the fan has fault, it will alert.

**Smoke-sense alarming**

When fireworks situation happens, the smoke-sense alarming signals will start alarm system to guarantee the safety of the machine. Also the unit has reset function to ensure give no false alarm.



**Environmental protection refrigerants**

Use freon-free environmental-protection refrigerants instead of traditional refrigerants  
Green, Low carbon, More environmental protection.



**Miniaturization designing, energy saving.**

Miniaturization and exquisite designing, easy to install. Specificly to control the devices internal temperature, energy saving and environmental protection



**Remote control**

The air conditioner can communicate with computer through RS485 connecting port. The user can check the running status of the air conditioner from the computer, and change parameters of the air conditioner.



DKC03/B  
DKC03W

DKC06/B  
DKC06W

DKC10/W  
DKC20/F

Model		DKC03/B	DKC03W	DKC06/B	DKC06W	DKC10W	DKC20/F
Refrigerant		R134a	R134a	R134a	R134a	R134a	R22
Cooling capacity	W	350	350	650	650	1000	2000
Power supply		1,220.50	1,220.50	1,220.50	1,220.50	1,220.50	1,220.50
Rated cooling power input	W	215	215	310	310	500	950
Rated operating current	A	1	1	1.4	1.4	2.3	4.3
Net weight	kg	15	15	24	24	42	45
Packing weight	kg	17	17	26	26	45	48
Noise	db(A)	55	55	55	55	55	55
Net Dimension (DxWxH)	mm	398×200×493	398×200×493	455×188×648	455×188×648	474×202×1150	474×202×1150
Packing Dimension (DxWxH)	mm	477×321×550	477×321×550	527×321×705	527×321×705	510×267×1240	510×267×1240
Loading Quantity (set)	20'40HQ	336/700/700	336/700/700	230/465/465	230/465/465	88/176/352	88/176/352

Remark: Test condition: Inside dry-bulb temperature 24°C, wet-bulb temperature 17°C, outside dry-bulb temperature 35°C.

- The data listed in the form only for reference, and the specific parameter shall refer to product nameplates.
- The applicable area of air conditioner is related to room orientation, insulation level, height of the building, the size and amount of the doors and windows, so that the applicable area is just for reference.
- Chunlian reserves the right to change the product design, specifications, and parameters. There is no specific notice if there appears any adjustment, please refer to product specifications and product nameplates.



Air-Source Water Heater

Quickly hot water outlet

The change from 2 hours to 1 minute, Chunlan thermal type air-source water heater adopts the high efficient and energy saving pipe heat exchanger for disposable heating to satisfy the users' requirements, it can supply water rapidly(1-3 minutes can supply hot water), it changes the traditional storage water heater (with water tank) which needs to heat water before 2 hours, and realizes the great change from 2 hours to 1 minute, thus making supply water become more convenient and more relaxed!



High efficient, energy saving

Chunlan air-source water heater uses small amount of power for driving force, making hot water through absorbing heat from the air. The EER can reach up to 3.8, comparing to the ordinary air-source water heater.

High-efficient heat exchanger

Equipped with unique patented technological long spiral casing heat exchanger, improving the heat transfer efficiency, and compared to ordinary casing heat exchanger, the heat exchange area is larger and the heat exchange efficiency is better.

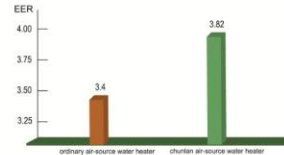

Instant heating, no water tank

Chunlan instant heating type air-source water heater adopts the high efficient and energy saving pipe heat exchanger for disposable heating to satisfy the users' requirements. It has no water tank, easy to install and can save space, it provides a comfortable life with hot water.



Continuous Water Flow

Chunlan promptly heating type air-source water heater has super water flow, within 24 hours of continuous uninterrupted hot water yield up to 6000 liters. You can enjoy bathing as you wishes.



Model		KD116/Y(250)	KF32/J(70)	KF46/J(100)
Refrigerant		R22	R22	R22
Heating Capacity	w	11600	3200	4600
Water supply	L/h	250-670	70	100
Power Supply	PH, V, Hz	1, 220, 50	1, 220, 50	1, 220, 50
Rated Heating Power Input	w	2950	910	1310
Rated Heating Operating Input	A	13	4.1	6.0
Noise Level	dB(A)	20-56	49	52
Net Dimensions WxDxH	mm	1033x337x745	650x250x506	760x259x537
Net Weight (kg)	kg	82	25	31
Packing Dimensions WxDxH	mm	1125x420x875	775x345x545	885x346x592
Gross Weight	kg	90	33	39
Water Tank Optional		no necessary	yes	yes

- The data listed in the form only for reference, and the specific parameter shall refer to product nameplates.
- The applicable area of air conditioner is related to room orientation, insulation level, height of the building, the size and amount of the doors and windows, so that the applicable area is just for reference.
- Chunlan reserves the right to change the product design, specifications, and parameters. There is no specific notice if there appears any adjustment, please refer to product specifications and product nameplates.



Dehumidifier

**Strong dehumidifying capability**

The high efficiency compressor and high quality heat exchanger ensure the excellent dehumidifying performance to keep dry and comfortable. With accelerated dehumidifying circulation and wide angle blow function, even if the airflow direction changes, it can still enhance the dehumidifying efficiency.



**Low temperature dehumidifying**

Ultra-low temperature dehumidifying starts while microcomputer auto defrosts, which produces a perfect solution that when the temperature is below 18 °C the dehumidifier cannot work due to the frost in exchanger surface, ensures dehumidifying above 5°C and the continuing work under low temperature ,meeting the using need in different environment.



**Intelligent humidity regulation**

When the humidity is out of limit, the sensitive humidity sensor will be aware of it and start dehumidifying. When the humidity reaches the setting state, the machine will stop working automatically.

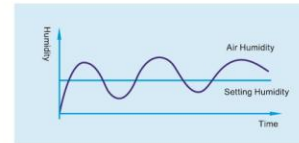

**Double layer long-life filter**

Mouldproof filter, antibacterial fiber double defense, bacteriostatic mouldproof, air impurity classification filtering, dedusting and dispelling peculiar smell, providing more pure and fresh air.



**Manual/Auto operating**

Choice in two modes between Manual and automatic to meet the dehumidifying need in different situation and seasons.



**Accurate dehumidifying performance**

Ensuring a humidity constant of indoor air through the automatic induction device and microcomputer control board.

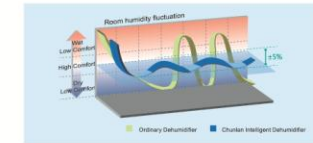

**High efficient operation**

Computer controls the dehumidifying operation and makes the whole process of dehumidifying in the state of high-efficient operation and environment friendly.

**High reliability**

Upholding the Chunlan quality control system, the shell uses the high-quality anti-corrosion proof technology as well as strict material selection and precise testing to ensure a more sustainable time of use.

Application Area

scientific research, industry, transportation, medical and health service, goods storage, underground construction, library, archives and other places.

The computation of dehumidifier's applicable area should consider building structure, height and humidity-control requirements, etc. Generally recommend applicable area can refer to technical parameter list.

Applicable working range of normal temperature type: 18 ~ 35 °C.

Applicable working range of low temperature type: 5 ~ 35 °C.



C2DE-6/E-S

CDE-6/C-S



C2DE-3

CDE-3/A

Model		C2DE-3	C2DE-6/E-S	CDE-3/A	CDE-6/C-S
Dehumidifying Capacity	(Kg/h) RH60%	3	6	3	6
Noise level	dB(A)	55	58	54	57
Air Flow	m3/h	850	1500	850	1500
Charge	(Kg)	0.9(R22)	1.55(R22)	0.9(R22)	1.55(R22)
Power Supply	PH,V,Hz	1PH,220V,50Hz	3PH,380V,50Hz	1PH,220V,50Hz	3PH,380V,50Hz
Rated Power Input	(w)	1850	2800	1850	2800
Rated Current Input	(A)	8.5	5.75	8.5	5.75
Operation Temperature	°C	5-32	5-32	18-32	18-32
Net (Gross) Weight	(Kg)	58/60	100/105	56/60	100/105
Net Dimensions	(D×W×H mm)	516x398x946	600x400x1800	516x398x946	600x400x1800
Packing Dimensions	(D×W×H mm)	596x455x1000	690x495x1950	596x455x1000	690x495x1950
Applicable Area	m <sup>2</sup>	20-40	50-80	20-40	50-80
Loading Quantity(set)		20/40/40H	36/74/74	90/198/198	36/74/74
Normal Conditions		Dry-bulb temperature 27.0°C, wet-bulb temperature 21.2°C; max load condition: dry-bulb temperature 32.0°C, wet-bulb temperature 23.0°C; low-temperature condition: dry-bulb temperature 5.0°C, wet-bulb temperature 2.1°C		Dry-bulb temperature 27.0°C, wet-bulb temperature 21.2°C; max load condition: dry-bulb temperature 32.0°C, wet-bulb temperature 23.0°C; low-temperature condition: dry-bulb temperature 18.0°C, wet-bulb temperature 13.5°C	

- The data listed in the form only for reference, and the specific parameter shall refer to product nameplates.
- The applicable area of air conditioner is related to room orientation, insulation level, height of the building, the size and amount of the doors and windows, so that the applicable area is just for reference.
- Chunlian reserves the right to change the product design, specifications, and parameters. There is no specific notice if there appears any adjustment, please refer to product specifications and product nameplates.